

# KEYSTONE

- 221 - Wafer style resilient seated butterfly valve
- 222 - Lugged style resilient seated butterfly valve
- Molded-in Seat Design

## Features and Benefits

- Molded-in resilient seat provides bubble-tight shutoff to 250 psi.
- Offered in two body styles: wafer and lug. The lugged body is drilled and tapped for isolation and removal of downstream piping at full rated pressure.
- Round, polished disc and hub edge provides 360 degree concentric seating, minimum flow restriction, lower torques and longer seat life.
- Upper and lower inboard bronze bearings ensure longer service life with low operating torques.
- Thru-stem design provides high strength and positive disc control with standardized end connection for operator interchangeability.
- Extended neck allows adequate clearance for flanges and insulation.
- Bidirectional, self-adjusting stem seal, located in the upper journal, is suitable for vacuum and pressure while also preventing external contamination of the stem area.
- Heavy-duty corrosion resistant top bushing, located in the upper journal, absorbs actuator side thrust.
- Cast-in top plate is an integral part of the body and is standardized to allow direct mounting of all Tyco actuators.
- Each valve is factory tested to 110 percent of specified pressure rating.



## General Application

Heating, ventilation, air conditioning and general industrial services.

## Technical Data

|                     |                                      |
|---------------------|--------------------------------------|
| Size Range:         | 2" thru 12"                          |
| Styles:             | 221 - wafer style<br>222 - lug style |
| Pressure Rating:    | 250 psi                              |
| Bidirectional       |                                      |
| Dead End Rating:    | 250 psi                              |
| Temperature Rating: | -40°F thru +250°F                    |
| Flange              |                                      |
| Accommodation:      | ASME 125/150                         |



Total Flow Control Solutions™

Keystone is either a trademark or registered trademark of Tyco International Services AG or its affiliates in the United States and/or other countries. All other brand names, product names, or trademarks belong to their respective holders.

# Keystone Butterfly Valves - Figure 221/222

2" thru 12"

## Materials

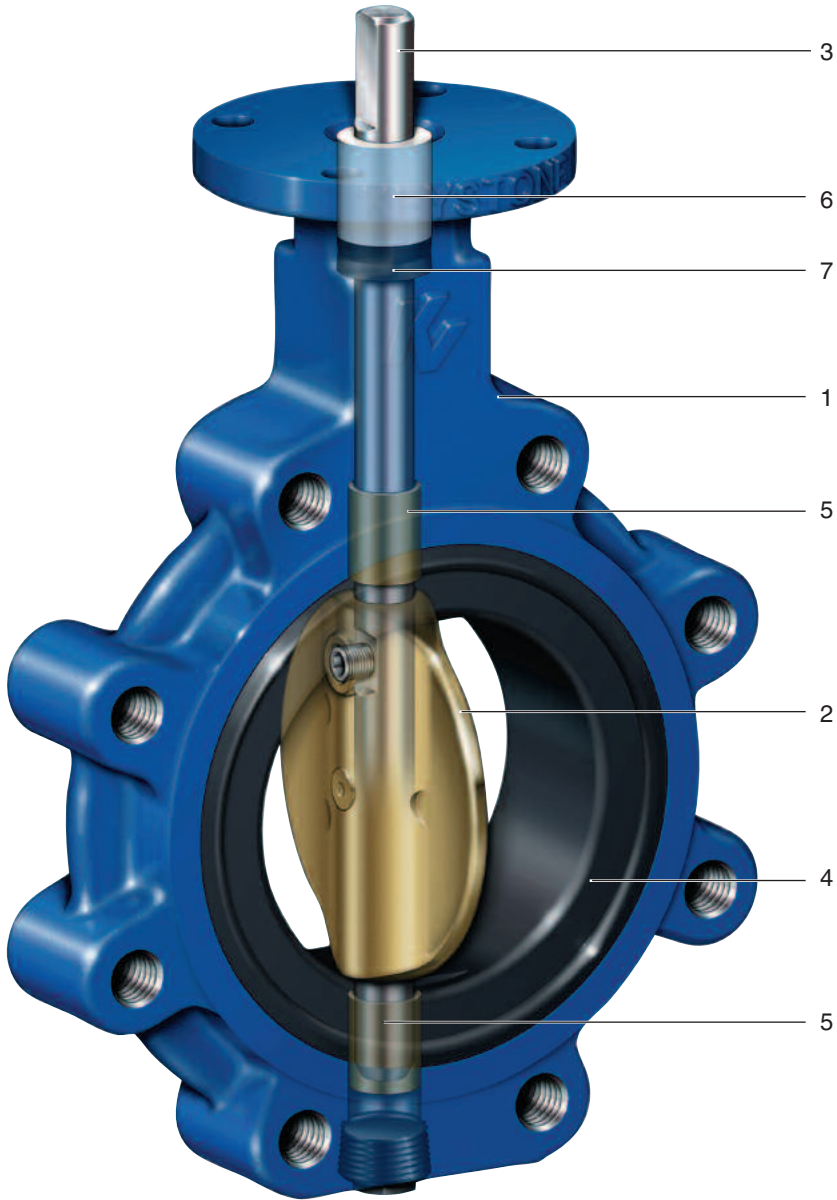

## Materials

| Part                | Material        | Material Standards           |
|---------------------|-----------------|------------------------------|
| 1. Body             | Cast Iron       | ASTM A126 Class B            |
| 2. Disc             | 304 SS          | ASTM A351 Grade CF8          |
|                     | Aluminum Bronze | ASTM B148 UNS C95200 Grade A |
|                     | 316 SS          | ASTM A743 Grade CF8M         |
| 3. Stem             | 416 SS          | ASTM A582<br>UNS S41600      |
| 4. Molded-in liner  | EPDM<br>NBR     |                              |
| 5. Inboard bearings | Bronze          |                              |
| 6. Upper bushing    | Polyester       |                              |
| 7. Upper stem seal  | NBR             |                              |

Dimensions

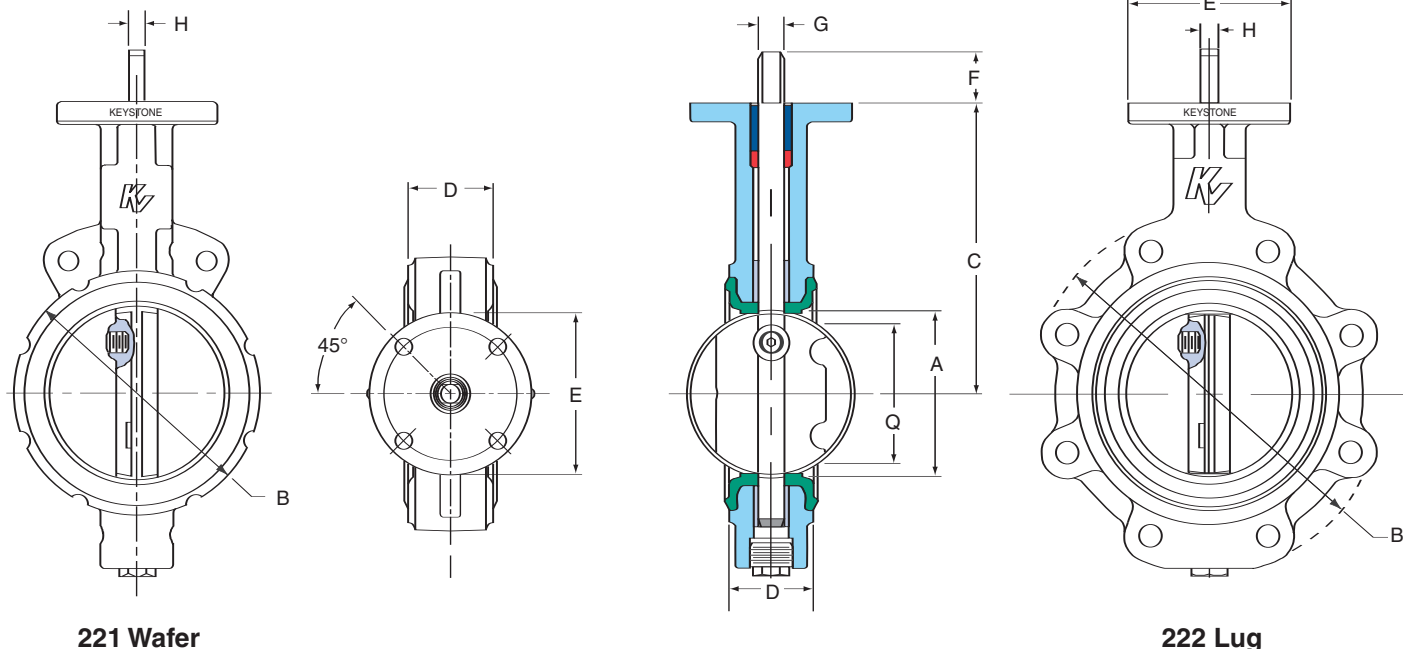

Figure 221 Dimensions (inches)

| Size                          | A                                | B                                | C                               | D                               | Q                               | E | F                             | G                              | H                              | Key   | Top Plate Drilling            |           |                                | Weight (lbs.) | Adapt. Code |
|-------------------------------|----------------------------------|----------------------------------|---------------------------------|---------------------------------|---------------------------------|---|-------------------------------|--------------------------------|--------------------------------|---|-------------------------------|-----------|--------------------------------|---------------|-------------|
|                               |                                  |                                  |                                 |                                 |                                 |   |                               |                                |                                |   | Bolt Circle                   | No. Holes | Hole Diam.                     |               |             |
| 2                             | 2 <sup>1</sup> / <sub>16</sub>   | 4 <sup>1</sup> / <sub>8</sub>    | 5 <sup>5</sup> / <sub>16</sub>  | 1 <sup>11</sup> / <sub>16</sub> | 1 <sup>3</sup> / <sub>8</sub>   | 4 | 1 <sup>1</sup> / <sub>4</sub> | 9 <sup>1</sup> / <sub>16</sub> | 3 <sup>3</sup> / <sub>8</sub>  | N/A   | 3 <sup>1</sup> / <sub>4</sub> | 4         | 7 <sup>1</sup> / <sub>16</sub> | 7.7           | BAB         |
| 2 <sup>1</sup> / <sub>2</sub> | 2 <sup>9</sup> / <sub>16</sub>   | 4 <sup>5</sup> / <sub>8</sub>    | 5 <sup>15</sup> / <sub>16</sub> | 1 <sup>13</sup> / <sub>16</sub> | 2                               | 4 | 1 <sup>1</sup> / <sub>4</sub> | 9 <sup>1</sup> / <sub>16</sub> | 3 <sup>3</sup> / <sub>8</sub>  | N/A   | 3 <sup>1</sup> / <sub>4</sub> | 4         | 7 <sup>1</sup> / <sub>16</sub> | 8.8           | BAB         |
| 3                             | 3 <sup>1</sup> / <sub>16</sub>   | 5 <sup>3</sup> / <sub>16</sub>   | 6 <sup>5</sup> / <sub>16</sub>  | 1 <sup>13</sup> / <sub>16</sub> | 2 <sup>5</sup> / <sub>8</sub>   | 4 | 1 <sup>1</sup> / <sub>4</sub> | 9 <sup>1</sup> / <sub>16</sub> | 3 <sup>3</sup> / <sub>8</sub>  | N/A   | 3 <sup>1</sup> / <sub>4</sub> | 4         | 7 <sup>1</sup> / <sub>16</sub> | 10.2          | BAB         |
| 4                             | 4 <sup>1</sup> / <sub>16</sub>   | 6 <sup>3</sup> / <sub>8</sub>    | 7 <sup>1</sup> / <sub>8</sub>   | 2 <sup>1</sup> / <sub>16</sub>  | 3 <sup>11</sup> / <sub>16</sub> | 4 | 1 <sup>1</sup> / <sub>4</sub> | 5 <sup>8</sup> / <sub>16</sub> | 7 <sup>1</sup> / <sub>16</sub> | N/A   | 3 <sup>1</sup> / <sub>4</sub> | 4         | 7 <sup>1</sup> / <sub>16</sub> | 16.9          | BAC         |
| 5                             | 5 <sup>1</sup> / <sub>16</sub>   | 7 <sup>3</sup> / <sub>8</sub>    | 7 <sup>11</sup> / <sub>16</sub> | 2 <sup>1</sup> / <sub>4</sub>   | 4 <sup>3</sup> / <sub>4</sub>   | 4 | 1 <sup>1</sup> / <sub>4</sub> | 3 <sup>4</sup> / <sub>16</sub> | 1 <sup>1</sup> / <sub>2</sub>  | N/A   | 3 <sup>1</sup> / <sub>4</sub> | 4         | 7 <sup>1</sup> / <sub>16</sub> | 19.9          | BAD         |
| 6                             | 5 <sup>13</sup> / <sub>16</sub>  | 8 <sup>1</sup> / <sub>2</sub>    | 8 <sup>5</sup> / <sub>16</sub>  | 2 <sup>1</sup> / <sub>4</sub>   | 5 <sup>9</sup> / <sub>16</sub>  | 4 | 1 <sup>1</sup> / <sub>4</sub> | 3 <sup>4</sup> / <sub>16</sub> | 1 <sup>1</sup> / <sub>2</sub>  | N/A   | 3 <sup>1</sup> / <sub>4</sub> | 4         | 7 <sup>1</sup> / <sub>16</sub> | 25.3          | BAD         |
| 8                             | 7 <sup>13</sup> / <sub>16</sub>  | 10 <sup>11</sup> / <sub>16</sub> | 9 <sup>1</sup> / <sub>2</sub>   | 2 <sup>3</sup> / <sub>8</sub>   | 7 <sup>3</sup> / <sub>4</sub>   | 6 | 1 <sup>1</sup> / <sub>4</sub> | 7 <sup>8</sup> / <sub>16</sub> | 5 <sup>8</sup> / <sub>16</sub> | N/A   | 5                             | 4         | 9 <sup>1</sup> / <sub>16</sub> | 40.5          | CAE         |
| 10                            | 9 <sup>13</sup> / <sub>16</sub>  | 13                               | 10 <sup>7</sup> / <sub>8</sub>  | 2 <sup>11</sup> / <sub>16</sub> | 9 <sup>3</sup> / <sub>4</sub>   | 6 | 2                             | 1 <sup>1</sup> / <sub>8</sub>  | N/A                            | 1 <sup>1</sup> / <sub>4</sub> x 1 <sup>1</sup> / <sub>4</sub> | 5                             | 4         | 9 <sup>1</sup> / <sub>16</sub> | 61.1          | CAF         |
| 12                            | 11 <sup>13</sup> / <sub>16</sub> | 14 <sup>13</sup> / <sub>16</sub> | 12 <sup>1</sup> / <sub>4</sub>  | 3 <sup>1</sup> / <sub>8</sub>   | 11 <sup>3</sup> / <sub>4</sub>  | 6 | 2                             | 1 <sup>1</sup> / <sub>8</sub>  | N/A                            | 1 <sup>1</sup> / <sub>4</sub> x 1 <sup>1</sup> / <sub>4</sub> | 5                             | 4         | 9 <sup>1</sup> / <sub>16</sub> | 82.7          | CAF         |

Figure 222 Dimensions (inches)

| Size                          | A                                | B                                | C                               | D                               | Q                               | E | F                             | G                              | H                              | Key   | Top Plate Drilling            |           |                                | Tapped Lug Data                |           |   | Weight (lbs.) | Adapt. Code |
|-------------------------------|----------------------------------|----------------------------------|---------------------------------|---------------------------------|---------------------------------|---|-------------------------------|--------------------------------|--------------------------------|---|-------------------------------|-----------|--------------------------------|--------------------------------|-----------|---|---------------|-------------|
|                               |                                  |                                  |                                 |                                 |                                 |   |                               |                                |                                |   | Bolt Circle                   | No. Holes | Hole Diam.                     | Bolt Circle                    | No. Holes | Tap                                       |               |             |
| 2                             | 2 <sup>1</sup> / <sub>16</sub>   | 4 <sup>3</sup> / <sub>4</sub>    | 5 <sup>5</sup> / <sub>16</sub>  | 1 <sup>11</sup> / <sub>16</sub> | 1 <sup>3</sup> / <sub>8</sub>   | 4 | 1 <sup>1</sup> / <sub>4</sub> | 9 <sup>1</sup> / <sub>16</sub> | 3 <sup>3</sup> / <sub>8</sub>  | N/A   | 3 <sup>1</sup> / <sub>4</sub> | 4         | 7 <sup>1</sup> / <sub>16</sub> | 4 <sup>3</sup> / <sub>4</sub>  | 4         | 5 <sup>8</sup> / <sub>16</sub> -11 UNC-2B | 9.0           | BAB         |
| 2 <sup>1</sup> / <sub>2</sub> | 2 <sup>9</sup> / <sub>16</sub>   | 5 <sup>1</sup> / <sub>4</sub>    | 5 <sup>15</sup> / <sub>16</sub> | 1 <sup>13</sup> / <sub>16</sub> | 2                               | 4 | 1 <sup>1</sup> / <sub>4</sub> | 9 <sup>1</sup> / <sub>16</sub> | 3 <sup>3</sup> / <sub>8</sub>  | N/A   | 3 <sup>1</sup> / <sub>4</sub> | 4         | 7 <sup>1</sup> / <sub>16</sub> | 5 <sup>1</sup> / <sub>2</sub>  | 4         | 5 <sup>8</sup> / <sub>16</sub> -11 UNC-2B | 10.5          | BAB         |
| 3                             | 3 <sup>1</sup> / <sub>16</sub>   | 5 <sup>13</sup> / <sub>16</sub>  | 6 <sup>5</sup> / <sub>16</sub>  | 1 <sup>13</sup> / <sub>16</sub> | 2 <sup>5</sup> / <sub>8</sub>   | 4 | 1 <sup>1</sup> / <sub>4</sub> | 9 <sup>1</sup> / <sub>16</sub> | 3 <sup>3</sup> / <sub>8</sub>  | N/A   | 3 <sup>1</sup> / <sub>4</sub> | 4         | 7 <sup>1</sup> / <sub>16</sub> | 6                              | 4         | 5 <sup>8</sup> / <sub>16</sub> -11 UNC-2B | 11.9          | BAB         |
| 4                             | 4 <sup>1</sup> / <sub>16</sub>   | 7                                | 7 <sup>1</sup> / <sub>8</sub>   | 2 <sup>1</sup> / <sub>16</sub>  | 3 <sup>11</sup> / <sub>16</sub> | 4 | 1 <sup>1</sup> / <sub>4</sub> | 5 <sup>8</sup> / <sub>16</sub> | 7 <sup>1</sup> / <sub>16</sub> | N/A   | 3 <sup>1</sup> / <sub>4</sub> | 4         | 7 <sup>1</sup> / <sub>16</sub> | 7 <sup>1</sup> / <sub>2</sub>  | 8         | 5 <sup>8</sup> / <sub>16</sub> -11 UNC-2B | 21.4          | BAC         |
| 5                             | 5 <sup>11</sup> / <sub>16</sub>  | 8 <sup>1</sup> / <sub>8</sub>    | 7 <sup>11</sup> / <sub>16</sub> | 2 <sup>1</sup> / <sub>4</sub>   | 4 <sup>3</sup> / <sub>4</sub>   | 4 | 1 <sup>1</sup> / <sub>4</sub> | 3 <sup>4</sup> / <sub>16</sub> | 1 <sup>1</sup> / <sub>2</sub>  | N/A   | 3 <sup>1</sup> / <sub>4</sub> | 4         | 7 <sup>1</sup> / <sub>16</sub> | 8 <sup>1</sup> / <sub>2</sub>  | 8         | 3 <sup>4</sup> / <sub>16</sub> -10 UNC-2B | 25.7          | BAD         |
| 6                             | 5 <sup>13</sup> / <sub>16</sub>  | 9 <sup>1</sup> / <sub>4</sub>    | 8 <sup>5</sup> / <sub>16</sub>  | 2 <sup>1</sup> / <sub>4</sub>   | 5 <sup>9</sup> / <sub>16</sub>  | 4 | 1 <sup>1</sup> / <sub>4</sub> | 3 <sup>4</sup> / <sub>16</sub> | 1 <sup>1</sup> / <sub>2</sub>  | N/A   | 3 <sup>1</sup> / <sub>4</sub> | 4         | 7 <sup>1</sup> / <sub>16</sub> | 9 <sup>1</sup> / <sub>2</sub>  | 8         | 3 <sup>4</sup> / <sub>16</sub> -10 UNC-2B | 31.0          | BAD         |
| 8                             | 7 <sup>13</sup> / <sub>16</sub>  | 11 <sup>7</sup> / <sub>16</sub>  | 9 <sup>1</sup> / <sub>2</sub>   | 2 <sup>3</sup> / <sub>8</sub>   | 7 <sup>3</sup> / <sub>4</sub>   | 6 | 1 <sup>1</sup> / <sub>4</sub> | 7 <sup>8</sup> / <sub>16</sub> | 5 <sup>8</sup> / <sub>16</sub> | N/A   | 5                             | 4         | 9 <sup>1</sup> / <sub>16</sub> | 11 <sup>3</sup> / <sub>4</sub> | 8         | 3 <sup>4</sup> / <sub>16</sub> -10 UNC-2B | 48.0          | CAE         |
| 10                            | 9 <sup>13</sup> / <sub>16</sub>  | 13 <sup>7</sup> / <sub>8</sub>   | 10 <sup>7</sup> / <sub>8</sub>  | 2 <sup>11</sup> / <sub>16</sub> | 9 <sup>3</sup> / <sub>4</sub>   | 6 | 2                             | 1 <sup>1</sup> / <sub>8</sub>  | N/A                            | 1 <sup>1</sup> / <sub>4</sub> x 1 <sup>1</sup> / <sub>4</sub> | 5                             | 4         | 9 <sup>1</sup> / <sub>16</sub> | 14 <sup>1</sup> / <sub>4</sub> | 12        | 7 <sup>8</sup> / <sub>16</sub> -9 UNC-2B  | 75.8          | CAF         |
| 12                            | 11 <sup>13</sup> / <sub>16</sub> | 15 <sup>11</sup> / <sub>16</sub> | 12 <sup>1</sup> / <sub>4</sub>  | 3 <sup>1</sup> / <sub>8</sub>   | 11 <sup>3</sup> / <sub>4</sub>  | 6 | 2                             | 1 <sup>1</sup> / <sub>8</sub>  | N/A                            | 1 <sup>1</sup> / <sub>4</sub> x 1 <sup>1</sup> / <sub>4</sub> | 5                             | 4         | 9 <sup>1</sup> / <sub>16</sub> | 17                             | 12        | 7 <sup>8</sup> / <sub>16</sub> -9 UNC-2B  | 106.5         | CAF         |

Note

'Q' dimension is the minimum allowable pipe or flange inside diameter at the centered body face to protect the disc sealing edge against damage when opening the valve.

# Keystone Butterfly Valves - Figure 221/222

2" thru 12"

## Valve $C_v$

| Size (in) | Size [mm] | 10° | 20° | 30° | 40° | 50°   | 60°   | 70°   | 80°   | 90°   |
|-----------|-----------|-----|-----|-----|-----|-------|-------|-------|-------|-------|
| 2         | 50        | 0   | 1.3 | 5   | 14  | 26    | 40    | 52    | 59    | 60    |
| 2½        | 65        | 0   | 1.4 | 6   | 21  | 44    | 74    | 107   | 138   | 150   |
| 3         | 80        | 0   | 1.5 | 8   | 29  | 67    | 115   | 175   | 234   | 262   |
| 4         | 100       | 1   | 15  | 48  | 107 | 196   | 318   | 463   | 589   | 647   |
| 5         | 125       | 3   | 32  | 99  | 206 | 362   | 579   | 832   | 1,045 | 1,141 |
| 6         | 150       | 4   | 47  | 145 | 295 | 510   | 810   | 1,160 | 1,450 | 1,580 |
| 8         | 200       | 6   | 84  | 239 | 450 | 751   | 1,190 | 1,754 | 2,385 | 2,892 |
| 10        | 250       | 9   | 133 | 360 | 652 | 1,064 | 1,683 | 2,524 | 3,596 | 4,593 |
| 12        | 300       | 12  | 192 | 509 | 899 | 1,449 | 2,288 | 3,470 | 5,085 | 6,682 |

## Note

$C_v$  is the valve flow capacity expressed as the flow rate of 60°F water, in US gallons per minute, which produces a 1 psi pressure drop across the valve.

[www.keystonevalves.com](http://www.keystonevalves.com)

[www.tycoflowcontrol.com](http://www.tycoflowcontrol.com)

Tyco Flow Control (TFC) provides the information herein in good faith but makes no representation as to its comprehensiveness or accuracy. This data sheet is intended only as a guide to TFC products and services. Individuals using this data sheet must exercise their independent judgment in evaluating product selection and determining product appropriateness for their particular purpose and system requirements. TFC MAKES NO REPRESENTATIONS OR WARRANTIES, EITHER EXPRESS OR IMPLIED, INCLUDING WITHOUT LIMITATION ANY WARRANTIES OF MERCHANTABILITY OR FITNESS FOR A PARTICULAR PURPOSE WITH RESPECT TO THE INFORMATION SET FORTH HEREIN OR THE PRODUCT(S) TO WHICH THE INFORMATION REFERS. ACCORDINGLY, TFC WILL NOT BE RESPONSIBLE FOR DAMAGES (OF ANY KIND OR NATURE, INCLUDING INCIDENTAL, INDIRECT, OR CONSEQUENTIAL DAMAGES) RESULTING FROM THE USE OF OR RELIANCE UPON THIS INFORMATION. Patents and Patents Pending in the U.S. and foreign countries. Tyco reserves the right to change product designs and specifications without notice.