

HANCOCK

Direct contact, metal-to-metal seating, make the globe valve ideal for most shutoff applications.

Features

- Heavy integral Stellite hardfacing on both body and disc seating surfaces.
- Conical seat, line contact seating.
- Socket weld ends are available as standard.
- All valves feature “No Bonnet Joint” design.
- Standard body materials are carbon steel (ASME SA105), alloy steel (ASME SA 182 Gr. F22).
- Small bodies (1" and smaller) are machined from forged bar.
- Larger sizes manufactured using die forgings.
- All yokes are made from die forged materials.
- GRAFOIL® packing with braided graphite non-extrusion rings on top and bottom.
- All 7000 Series valves are available in ANSI Standard and Limited Classes and are in full compliance with Section 1 of the ASME Boiler and Pressure Vessel Code and ASME/ANSI B16.34.



Sizes

- 1/2" - 2 1/2": Class 1690
STD and LTD
- : Class 2680
STD and LTD
- : Class 4350
STD and LTD

Options

- Motor operators
- Handwheel
- Impact handles and handwheels

tyco / Flow Control

Total Flow Control Solutions™

GRAFOIL® is a registered trademark of Graftech, Inc.

Hancock is either a trademark or registered trademark of Tyco International Services AG or its affiliates in the United States and/or other countries. All other brand names, product names, or trademarks belong to their respective holders.

Features

Rugged Malleable Iron T-handle - standard on smaller valves. Impactor handwheels on larger models. Handwheels are available for any size valve. Tapered squared stem and socket and extra length handles provide slip free operation, even in tight spaces.

Silicon Brass Thread Bushing - made from high strength, anti-galling silicon brass and threaded for easy removal and replacement.

ACME Threads - for strength, wear-resistance and ease of operation.

Standard Hex Gland Nuts - easily adjusted with standard tools.

Forged Steel Gland Flange - high strength, forged alloy steel gland flanges are standard. Ball joint design eliminates gland misalignment.

Rugged Stainless Steel Stem - heat treated and precision ground for long packing life, ease of operation and resistance to galling and corrosion. Stem is suitable for service at over 1000°F.

"No Bonnet Joint" Design - body and yoke are fabricated with a full penetration weld. No crevices where corrosion can occur. Eliminates gaskets. Fully repairable without cutting weld.

Forged Steel Construction - full compliance with ASME Boiler and Pressure Vessel Code, Section I design and material requirements.

Precision Machined Disc Assembly - Accurately machined disc, disc retainer and disc pad provide accurate guiding of the disc through the full valve stroke. Disc is hardfaced for maximum seat life.

Stellite Disc Pad Bearing - ensures disc rotation, prevents galling and disc seizure. Prolongs seat life.

Renewable Hard Faced Seats - Stellite or equal is standard on all 7000 Series valves. Extra heavy overlay allows for repeated refinishing.

Smooth, High Flow Port Design - Large port diameters with minimum changes in direction in flow passages allow for high flow rates and minimum pressure drop spaces.

Precision Handle Locknut - standard on all sizes, can't vibrate loose. Holds handle tightly to tapered, squared stem, eliminating play.

Integral Forged Yoke - spring-action yoke arms compensate for temperature changes, assuring tight shutoff.

Two-Piece Packing Gland - for ease of repacking. Silicon brass material prevents stem abrasion damage.

Graphite Packing Rings - built in corrosion inhibitor for leak tight sealing in high and low temperature applications.

Non-Extrusion Rings - prevent packing migration and ensure long service life in high temperature and high pressure applications.

Stainless Steel Packing Stop Ring - prevents packing extrusion.

Fixed or Loose Backseat Design - optional on all 7000 Series Stop Valves. Heat treated yoke bushing and retainer nut for gall-resistant stem guiding.

End Connections per ASME B16.34 - Valves are available with socket weld ends as standard.

Tapered Seat Configuration - permits automatic seat and disc alignment. improved flow capacity and smooth throttling control during initial opening.

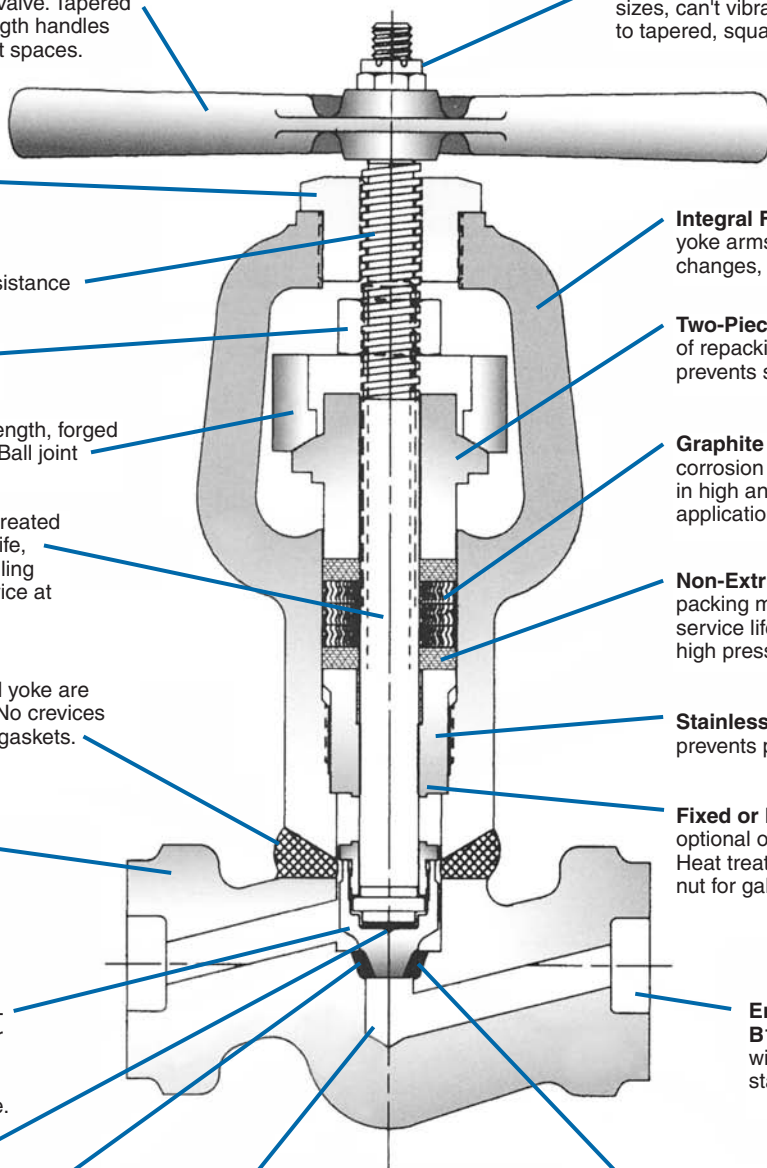

Loose Backseat Configuration

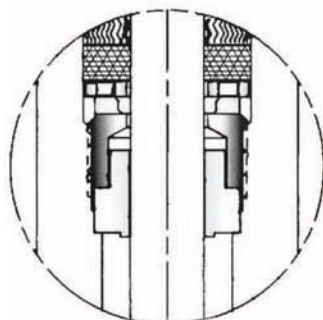

Fixed Backseat Configuration

Full Code Compliance

Hancock 7000 Series T-Pattern valves are designed, manufactured and tested in compliance with the requirements of ASME/ANSI B16.34, as well as the ASME Boiler and Pressure Vessel Code, Section 1.

General Description

Direct contact, metal-to-metal seating makes this globe valve ideal for most shutoff applications. The basic design eliminates the inherent wedge gate valve problem of "wedge sticking" caused when high thermal transients or piping load stresses exert such force that the valve won't open. Positive, direct closure discs allow for accurate control over the initial portion of stem travel, permitting smooth, linear flow, thereby preventing mechanical and/or thermal shock to the valve, downstream piping or expensive machinery.

An outstanding feature of a conventional globe valve is its ability to handle flow around the full seat diameter from the instant it starts to open. The high velocities occurring during the initial opening of a conventional globe valve are distributed evenly and

simultaneously across the entire seating surface. It is this characteristic that helps protect the seating surfaces from erosion and helps to prevent high velocity fluid and cavitation from damaging the valve's downstream body walls or related piping.

The availability of metal-to-metal seating gives globe valves the ability to withstand high temperatures. Hard faced seats enhance the globe valve's ability to hold up in abrasive and high velocity environments. A wide variety of body and trim materials permit its use in severe and corrosive service applications.

The globe valve's top entry design makes it easy to service and maintain. T-Pattern designs, by virtue of their tortuous flow path, reduce velocity and are ideal where throttling is required during initial opening.

Selection

T-Pattern Globe Stop valves can be used in a wide variety of services and applications. They are especially well suited for applications requiring:

- Tight shutoff, high pressures and temperatures
- Slow initial opening times
- Rapid actuation or high speed remote operation
- Valve operation during, or after, high thermal or piping stress transient conditions
- Isolation, draining, venting or filling at high pressures and/or temperatures, while having to maintain tight shutoff at maximum operating conditions
- Pressure or temperature equalizing of systems or large valves

When selecting globe valves, utilization of a top entry design, with a non-welded bonnet closure, will permit easy access to internal components for service and parts replacement, without having to remove the valve from the line. The ability to make quick repairs is especially important at start-up time when valve damage from fabrication debris is most likely to cause expensive down time and project delays.

Materials of Construction

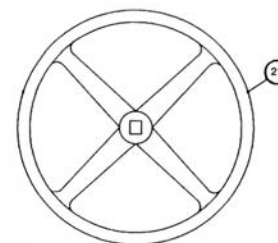
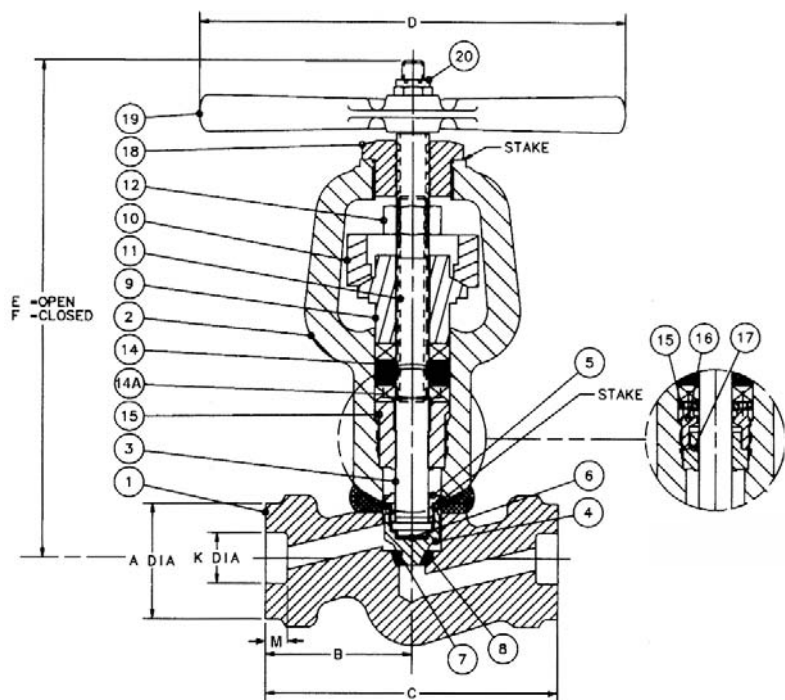

Handwheel

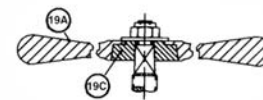

Impactor Handle

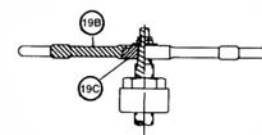

Impactor Handwheel

Loose Backseat - 7130

Fixed Backseat - 7150

No.	Part	Alloy Steel	Carbon Steel
1	Body	ASME SA182 Gr. F22	ASME SA105
2	Yoke	ASME SA182 Gr. F22	ASME SA105
3	Stem		ASTM A582 Type 416 Condition T
4	Disc		Stainless Steel ASTM A276 Type 410 Condition T
5	Disc Nut		Stainless Steel ASTM A276 Type 420, Heat Treated
6	Disc Pad		Alloy Steel -Haynes Alloy 25
7	Disc Facing (Integral)		Stellite 6 or equal
8	Seat Facing (Integral)		Stellite 6 or equal
9	Packing Gland ¹		Silicon Alloy/ASTM B371 Alloy 694
10	Packing Gland Flange		Carbon Steel ASTM A105
11	Packing Gland Stud		Alloy Steel ASTM A193 Gr. B7
12	Packing Gland Stud Nut		Carbon Steel/ASTM A194 Gr. 2H
13	Marker Plate		Stainless Steel
14	Packing		Compressed Graphite
14A	Non-Extrusion Ring		Braided Graphite Filament
15	Packing Stop Ring		Stainless Steel ASTM A276 Type 410 Condition T
16	Yoke Bushing		Stainless Steel ASTM A276 Type 420, Heat Treated
17	Yoke Bushing Nut		ASTM A582 Type 410 Stainless Steel, Heat Treated
18	Thread Bushing		ASTM B371 Alloy C69400 Silicon Brass
19	Handle		Malleable Iron ASTM A47 Gr. 32510
19A	Impactor Handle ²		Malleable Iron ASTM A47 Gr. 32510
19B	Impactor Handwheel ²		Malleable Iron ASTM A47 Gr. 32510
19C	Hi-Tork Bushing ²		Malleable Iron ASTM A47 Gr. 32510
20	Handle Nut		Carbon Steel, Self Locking Type
21	Handwheel ²		Malleable Iron ASTM A47 Gr. 32510

Notes

1. Split packing gland is made in two halves.
2. Optional item.

1690 Class Dimensions, Weights and C_v Values

Size	A	B	C	D	E	F	K	M	Weight Lbs.	C _v
1/2"	1.62	2.50	5.00	7.12	8.87	8.46	0.86	0.37	11	3.2
3/4"	1.62	2.50	5.00	8.12	11.25	10.63	1.07	0.50	18.5	4.9
1"	1.96	2.50	5.00	8.12	11.25	10.63	1.33	0.50	18.5	6.8
1 1/2"	2.91	4.25	8.50	12.50	16.75	15.31	1.92	0.50	52	23.0
2"	3.50	4.25	8.50	12.50	16.75	15.31	2.41	0.62	52	23.5
2 1/2" *										

2680 Class Dimensions, Weights and C_v Values

Size	A	B	C	D	E	F	K	M	Weight Lbs.	C _v
1/2"	1.62	2.50	5.00	7.12	8.18	7.75	0.86	0.37	11	0.91
3/4"	1.93	2.50	5.00	8.12	11.00	10.37	1.07	0.50	18.5	4.3
1"	2.25	2.50	5.00	8.12	11.00	10.37	1.33	0.50	18.5	4.2
1 1/2"	3.15	4.25	8.50	12.50	15.50	14.06	1.92	0.50	63.5	16.5
2"	3.93	4.25	8.50	12.50	15.50	14.06	2.41	0.62	63.5	16.5
2 1/2" *										

4350 Class Dimensions, Weights and C_v Values

Size	A	B	C	D	E	F	K	M	Weight Lbs.	C _v
1/2"	1.05	1.38	5.00	7.12	10.00	9.43	0.86	0.37	16	*
3/4"	1.28	1.75	5.00	8.12	13.00	12.06	1.07	0.50	26	3.0
1"	1.56	1.75	5.00	8.12	13.00	12.06	1.33	0.50	26	4.2
1 1/2"	2.17	2.38	8.50	12.50	16.81	15.37	1.92	0.50	77	10.0
2"	2.38	2.38	8.50	12.50	16.81	15.37	2.41	0.62	77	14.2
2 1/2"	2.69	2.69	8.50	12.50	16.81	15.37	2.91	0.62	99	*

* Consult Factory

Maintenance Features

Service and Repair Tools for In-Line Valve Maintenance

Hancock High Pressure “No Bonnet Joint” valves are designed to meet the requirements of the electrical power industry's high pressure/high temperature steam generating plants, as well as the high pressure requirements of the process industry. This valve's one piece body design offers simplicity of disassembly and maintenance without removing the valve from the line. There are NO BONNET BOLTS to undo, NO WELDS to break and NO GASKETS to replace.

The maintenance tools illustrated, and the procedures described in the maintenance manual are designed to facilitate in-line valve service and repair in a minimum of time, without sacrificing maintenance quality or requiring special training of maintenance personnel.

These valves offer design simplicity for long trouble-free service and easy in-line maintenance. In five simple steps the Hancock valve can be completely disassembled, ready for inspection and easily accessible for in-line repair.



Step #1: Upset material holding thread bushing to yoke is removed first, by filing.



Step #2: Packing gland nuts are then removed; gland flange is lifted and split glands removed. Thread bushing and handwheel nut are loosened.



Step #3: Using stem as a jack screw, it is turned as when opening valve, to lift packing out of stuffing box. When the last thread of the stem makes up on the thread bushing, bushing is backed off and split glands inserted, as shown in photo. This allows more jacking height when removing packing from stuffing box.



Step #4: Stem assembly is completely removed. Valve is ready for lapping.

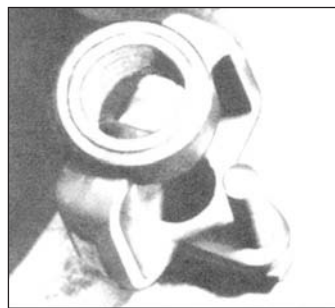

Step #5: Valve is completely disassembled, ready for inspection and accessible for repair, if necessary.

Ordering Information

Hancock Forged Steel Valves are available with a variety of standard and special materials, trims and operators. The diagram below is an explanation of Hancock figure numbers.

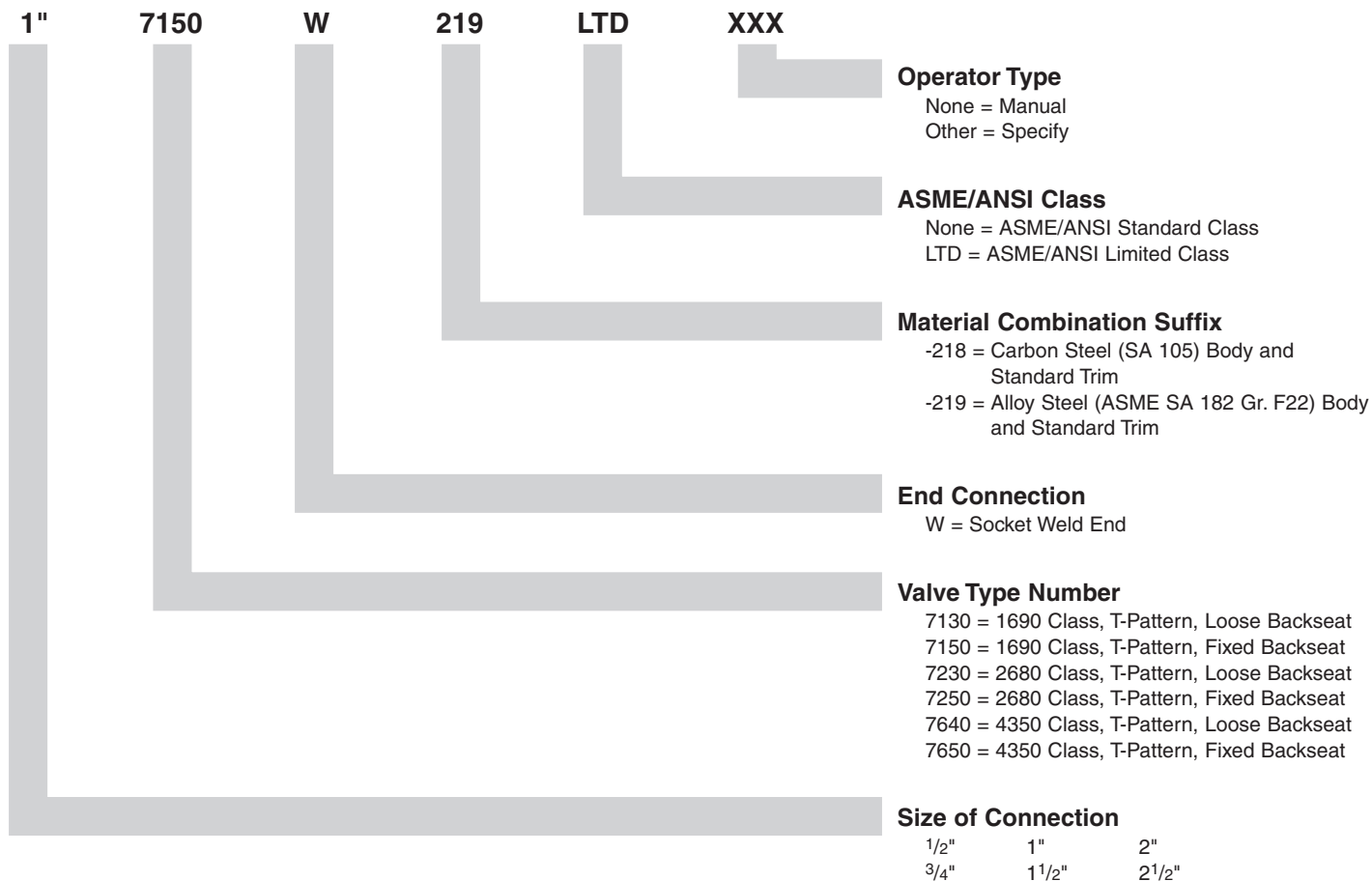

How to Order

When ordering Hancock High Pressure 7000 Series valves, please specify quantity, figure number and applicable data below:

- A. Quantity Required
- B. Nominal Valve Size
1/2", 3/4", 1", 1 1/2", 2", 2 1/2"
- C. ASME/ANSI Rating
1690 LTD
2680 LTD
4350 LTD
- D. Type of Valve
Hancock T-Pattern Globe Valve
- E. Valve Style
No Bonnet Joint, OS&Y, Loose Backseat
No Bonnet Joint, OS&Y, Fixed Backseat
- F. Body Material
ASME SA 105 Carbon Steel
ASME SA 182 Gr. F22 Alloy Steel
- G. Trim Material
13% Cr, Hardfaced Seat and Disc
- H. Type of End Connection
Socket Weld End
- I. Operator Type
Standard (T-Handle)
Handwheel
Motor
- J. Figure Number
See chart above
- K. Operating Conditions
Working Pressure
Working Temperature
Design Pressure
Design Temperature
Flow Media
Flow Capacity (if applicable)
- L. Operator Specifications
Electrical requirements
Manual override
Limit switch(es)

EXAMPLE: 2 each, 1 1/2" Hancock Figure No. 7150W-219, ANSI 1690 Class T-Pattern, No-Bonnet design globe valve, manually operated, OS&Y, ASME SA 182 Gr. F22 body with 13% chrome trim. Both seat and disc shall be integrally hardfaced with Stellite or equal. End connections shall be socket weld. Valves must meet the requirements of the ASME Boiler and Pressure Vessel Code, Section I and ASME/ANSI B16.34, and be suitable for the following service conditions:

Operating conditions:

Fluid = _____ at _____ psig and _____ °F;

Required flow rate = _____ lbs/hr

Design conditions: Fluid = _____ psig and °F;

Design flow rate = _____ lbs/hr

www.tycoflowcontrol.com

Tyco Flow Control (TFC) provides the information herein in good faith but makes no representation as to its comprehensiveness or accuracy. This data sheet is intended only as a guide to TFC products and services. Individuals using this data sheet must exercise their independent judgment in evaluating product selection and determining product appropriateness for their particular purpose and system requirements. TFC MAKES NO REPRESENTATIONS OR WARRANTIES, EITHER EXPRESS OR IMPLIED, INCLUDING WITHOUT LIMITATION ANY WARRANTIES OF MERCHANTABILITY OR FITNESS FOR A PARTICULAR PURPOSE WITH RESPECT TO THE INFORMATION SET FORTH HEREIN OR THE PRODUCT(S) TO WHICH THE INFORMATION REFERS. ACCORDINGLY, TFC WILL NOT BE RESPONSIBLE FOR DAMAGES (OF ANY KIND OR NATURE, INCLUDING INCIDENTAL, INDIRECT, OR CONSEQUENTIAL DAMAGES) RESULTING FROM THE USE OF OR RELIANCE UPON THIS INFORMATION. Patents and Patents Pending in the U.S. and foreign countries. Tyco reserves the right to change product designs and specifications without notice.