

HANCOCK®

Advanced construction features of this high pressure drop angle globe valve provide quality and long service life, Class 800 ANSI.

Features

- Rated to ASME/ANSI 800 Limited Class for use in all applications requiring 800 Limited Class ratings or below.
- Available in 1" nominal pipe size with 1/8", 3/16", 1/4" or 5/16" orifice, depending on desired flow capacities.
- A micrometer dial position indicator allows fast, precise and repeatable settings.
- Socket weld end connections.
- Both disc and disc seat are hard faced with Stellite for erosion resistance.
- Seating surfaces are ground and lapped for tight shut off, eliminating double valving requirements.
- The integral stem disc is faced with Stellite, then ground and lapped for accurate, leakfree sealing.
- The disc is tapered for maximum controllability over the full stroke of the valve.
- Standard material is carbon steel (ASME SA 105) body with 13% chrome stainless steel trim.
- One-piece drop forged body
- Graphite packing, complete with braided graphite filament yarn anti-extrusion rings, is standard.
- All Hancock 5505 series valves comply with ASME/ANSI B 16.34 and the ASME Boiler and Pressure Vessel Code, Section 1.



Applications

In addition to continuous blowdown service, the Hancock High Pressure Drop valve is also used on feedwater bypass relief, sampling systems, drains and other services where erosion is extremely severe.

Available Types

- 5505W Angle Body, Socket Weld to ASME B16.11

Size

1"

tyco / Flow Control

Total Flow Control Solutions™

Hancock is either a trademark or registered trademark of Tyco International Services AG or its affiliates in the United States and/or other countries. All other brand names, product names, or trademarks belong to their respective holders.

Features

Specifically designed to withstand the deleterious effects of continuous blowdown service so damaging to conventional valves. The high velocity stream of boiler water, flashing into steam, is forced to expend its kinetic energy within the confines of the diverging hardened stainless steel delivery tube, thus eliminating damage to the valve body wall and downstream piping.

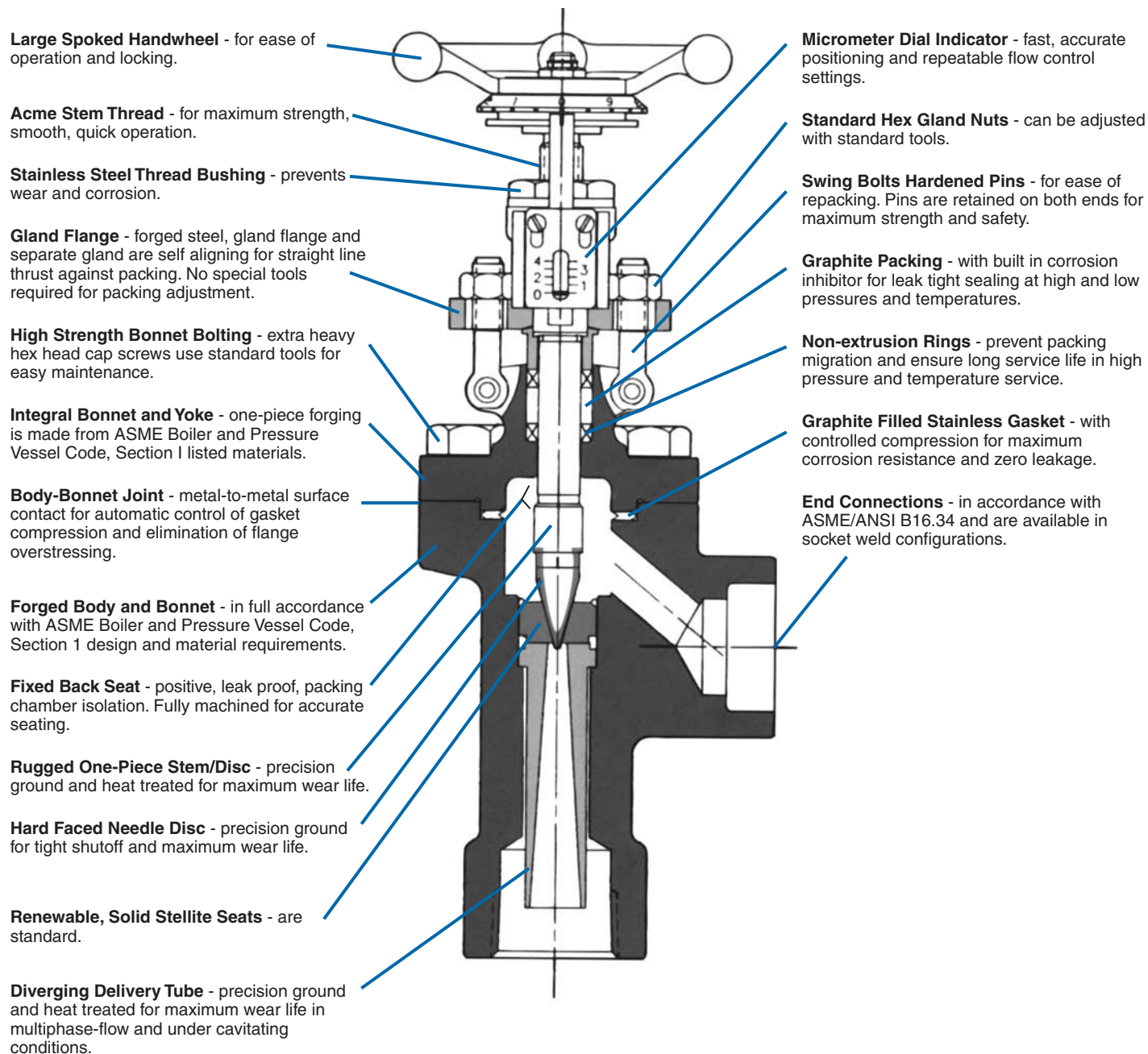

Hancock Series 5505

Continuous Blowdown Globe Valve

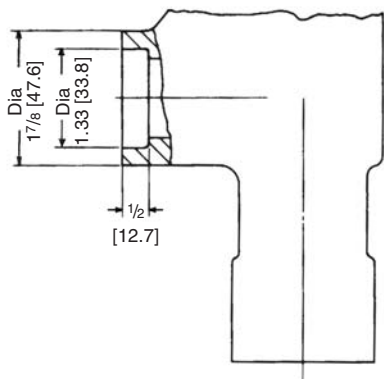
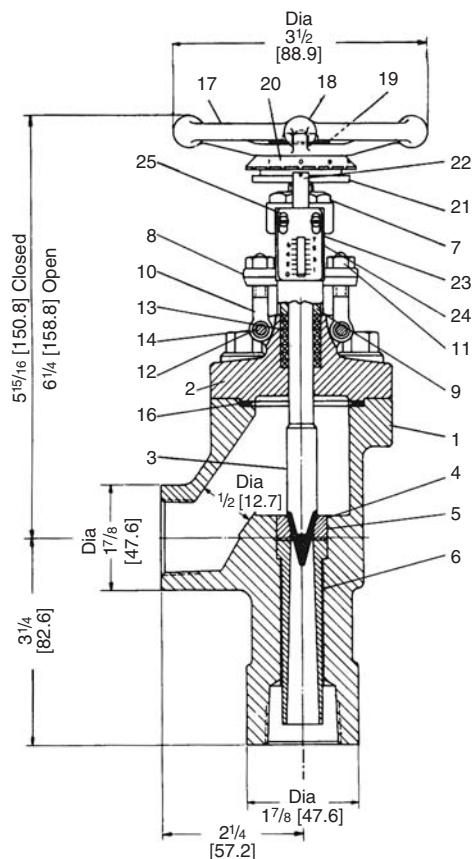

**Socket Weld Ends to ANSI 816.11
Type 5505W**

Note

1. Dimensions in inches [mm].

Materials of Construction

| No. | Part | Material | Specification |
|-----|----------------------|---------------------|------------------------------|
| 1 | Body | Forged Carbon Steel | ASME SA105 |
| 2 | Bonnet | Forged Carbon Steel | ASME SA105 |
| 3 | Stem | Stainless Steel | 410 Condition T |
| 4 | Stem Facing | Hard Facing | Stellite or Equal |
| 5 | Seat | Solid Stellite | Stellite or Equal |
| 6 | Tube | Stainless Steel | 347 |
| 7 | Thread Bushing | Stainless Steel | 410 Condition T |
| 8 | Packing Gland Flange | Carbon Steel | ASTM A105 |
| 9 | Packing Gland | Stainless Steel | 410 Condition T |
| 10 | Packing Gland Bolt | Stainless Steel | 410 HT |
| 11 | Packing Gland Nut | Carbon Steel | ASTM A194-2H |
| 12 | Pin | Stainless Steel | 410 HT |
| 13 | Packing Ring | Compressed Graphite | Corrosion Inhibited |
| 14 | Bonnet Bolt | Alloy Steel | ASTM A193 Gr. B-7 |
| 16 | Gasket | 304 Stainless Steel | Spiral Wound Graphite Filled |
| 17 | Handwheel | Ductile Iron | |
| 18 | Handwheel Nut | Carbon Steel | Lock-Type |
| 19 | Marker Plate | Etched Aluminum | - |
| 20 | Dial | Brass | - |
| 21 | Dial Plate | Brass | - |
| 22 | Indicator | Brass | - |
| 23 | Indicator Bracket | Aluminum | - |
| 24 | Indicator Plate | Aluminum | - |
| 25 | Indicator Plate | Screw Brass | - |

C_v Values Based on Percent of Opening

| Percent Open % | Flow Coefficient C _v | | | |
|----------------|---------------------------------|------|------|------|
| | Orifice Size | | | |
| | 1/8 | 3/16 | 1/4 | 5/16 |
| 10 | 0.06 | 0.11 | 0.17 | 0.28 |
| 20 | 0.13 | 0.24 | 0.36 | 0.60 |
| 30 | 0.19 | 0.35 | 0.56 | 0.94 |
| 40 | 0.24 | 0.43 | 0.73 | 1.22 |
| 50 | 0.29 | 0.52 | 0.90 | 1.50 |
| 60 | 0.34 | 0.62 | 1.05 | 1.75 |
| 70 | 0.40 | 0.72 | 1.20 | 2.00 |
| 80 | 0.43 | 0.78 | 1.30 | 2.18 |
| 90 | 0.46 | 0.83 | 1.40 | 2.32 |
| 100 | 0.48 | 0.87 | 1.50 | 2.50 |

Weight

8.2 pounds

Continuous Blowdown Chart - Wide Open

1" Figure Numbers 5505W Wide Open Capacities vs. Boiler Pressures (Reference #MM332)

Example 1: To determine the correct size orifice for an 800 Class Continuous Blowdown Valve which will flow 3500 lbs/hr at 800 psig inlet pressure.

- On the Continuous Blowdown-Wide Open chart to the right, locate 3,500 on the Blowdown Capacity scale and draw a horizontal line (a) across the chart from that point (see example below).
- Draw a vertical line (b) from 800 on the Boiler Pressure scale to intersect with the horizontal line (a).
- Continue the vertical line (c) until it intersects with the next higher orifice curve (in this case, $\frac{3}{16}$ ").
- Draw a horizontal line (d) from the intersection of the $\frac{3}{16}$ " orifice curve to the Blowdown Capacity line and read the maximum capacity of the $\frac{3}{16}$ " orifice valve (3800 lbs/hr).
- Check to ensure that the selected orifice will result in the correct valve position to allow for proper control without throttling too close to the seat (see steps F- H).
- On the Handwheel Turns vs Percent of Wide Open Capacities chart (see page 5), locate the $\frac{3}{16}$ " orifice curve and draw a vertical line (e) from where it intersects with the 100% open line down to the Handwheel Turns scale. Read the number of turns to reach maximum capacity of the valve (2 turns).
- Determine what percent of the full open capacity is required to attain the Normal required flow rate (Divide the Normal Required Flow Rate by the Maximum Flow Rate and multiply by 100 to obtain the correct percentage.) $3500/3800 \times 100 = 92\%$.
- Verify that the required flow rate will be obtained when the valve is between $\frac{1}{3}$ and $\frac{2}{3}$ open (in this case, between 0.66 and 1.33 full turns) by drawing a horizontal line (g) from the 92% point on the capacity scale to intersect with the $\frac{3}{16}$ " orifice curve. Then draw a vertical line (f) from that intersection to the Handwheel Turns scale and read the number of turns open (1.7) required to attain the specified flow (3500 lbs/hr).

Since 1.7 turns is much greater than the desired 1.33 and will result in little or no controllability, the next larger size orifice ($\frac{1}{4}$ ") should be utilized and the flow rate versus valve disc position reverified by repeating steps A through H.

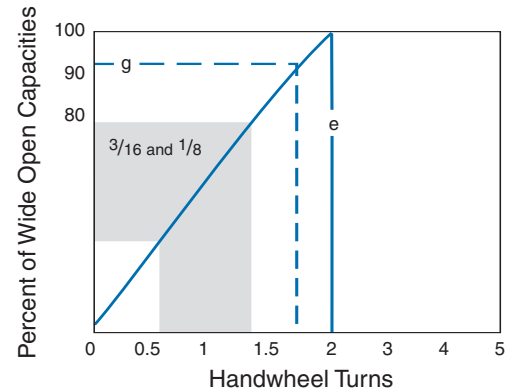
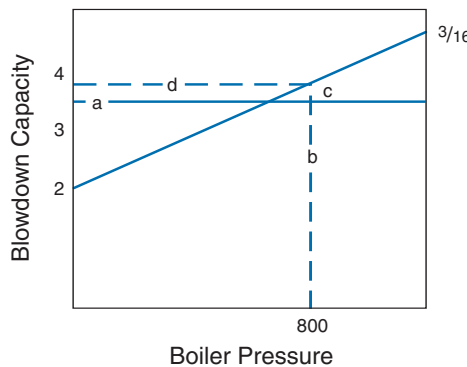
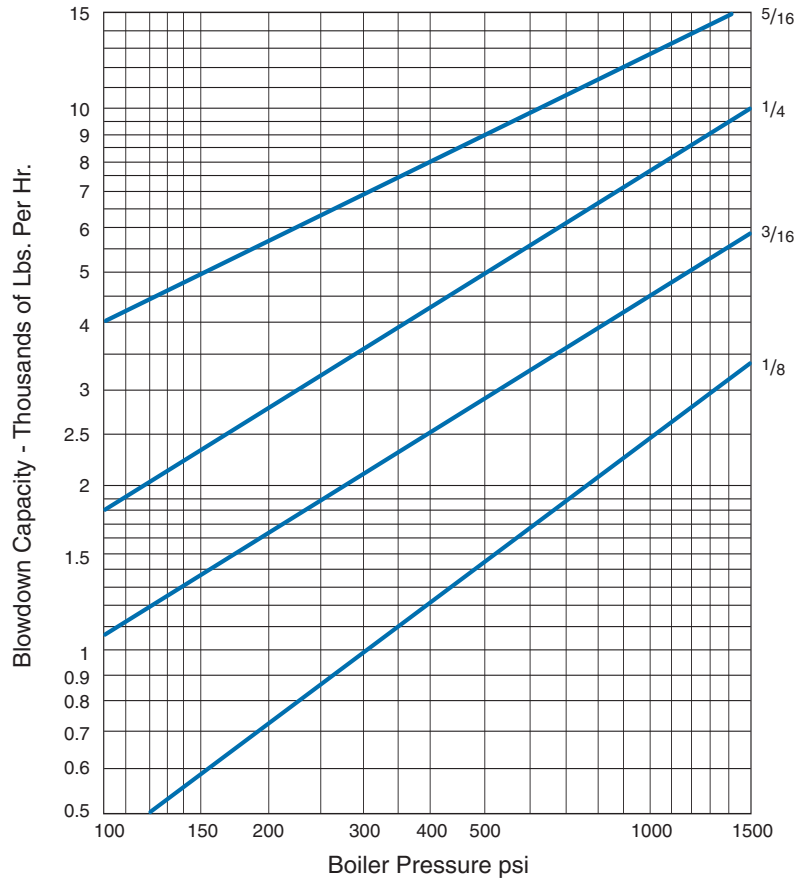

Continuous Blowdown Chart - Handwheel Turns

1" Figure Numbers 5505W Handwheel Turn vs Wide Open Capacities (Reference #MM334)

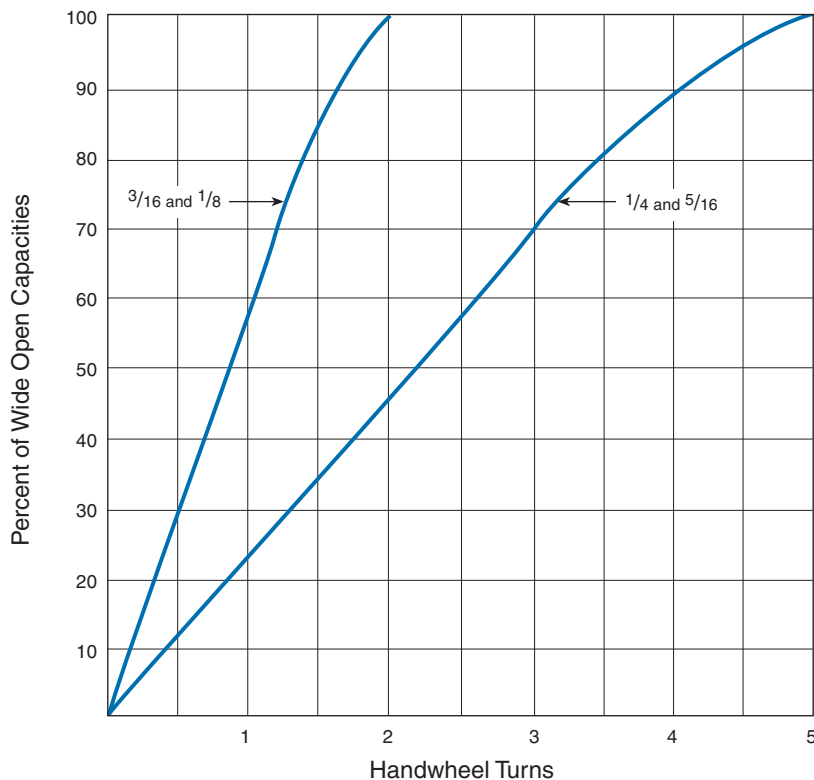

**Steam, Air, Gas
 Chart #1
 (Reference #MM336)**

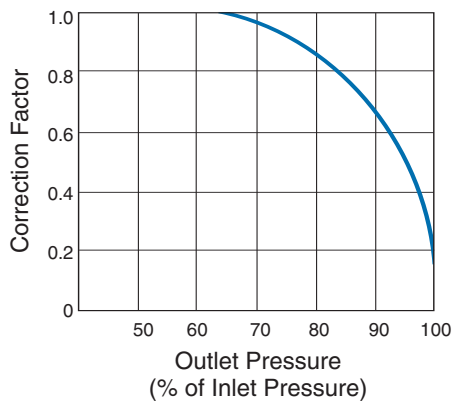

**Steam
 Chart #2
 (Reference #MM336)**

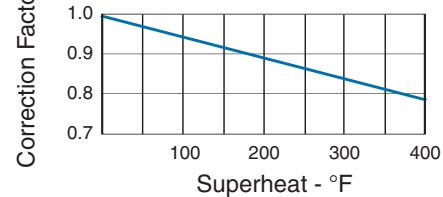

Water Flow Chart

1" Figure Numbers 5505W (Reference #MM341)

Example 1: To determine the correct size orifice for an 800 Class Continuous Blowdown Valve which will flow 6000 lbs/hr of water at 800 psig inlet pressure with a pressure drop of 400 psi:

- On the Water Flow chart to the right, locate 6000 on the Capacity scale and draw a horizontal line (a) across the chart from that point (see sample chart below).
- Draw a vertical line (b) from 400 on the Pressure Drop scale to intersect with the horizontal line (a).
- Continue the vertical line (c) until it intersects with the next higher orifice curve (in this case, $\frac{3}{16}$ ").
- Draw a horizontal line (d) from the intersection of the $\frac{3}{16}$ " orifice curve to the Capacity scale and read the maximum capacity of the $\frac{3}{16}$ " orifice valve (8800 lbs/hr).
- Check to ensure that the selected orifice will result in the correct valve position to allow for proper control without throttling too close to the seat (see steps F-H).
- On the Handwheel Turns vs Percent of Wide Open Capacities chart (see page 5), locate the $\frac{3}{16}$ " orifice curve and draw a vertical line (e) from where it intersects with the 100% open line down to the Handwheel Turns scale. Read the number of turns to reach maximum capacity of the valve (in this case, 2 turns).
- Determine what percent of the wide open capacity is required to attain the required flow rate. (Divide the required flow rate by the maximum flow rate and multiply by 100 to obtain the correct percentage.)
 $6000/8800 \text{ lbs/hr} \times 100 = 68\%$
- Verify that the required flow rate will be obtained when the valve is between $\frac{1}{3}$ and $\frac{2}{3}$ open (in this case, between 0.66 and 1.33 full turns) by drawing a horizontal line (g) from the 68% point on the capacity line to intersect with the $\frac{3}{16}$ " orifice curve. Then draw a vertical line (f) from that intersection down to the Handwheel Turns scale and read the number of turns open (1.2) required to attain the specified flow (6000 lbs/hr).

Since 1.2 turns falls between the optimum range of 0.66 and 1.33 turns, the $\frac{3}{16}$ " orifice is satisfactory for the application.

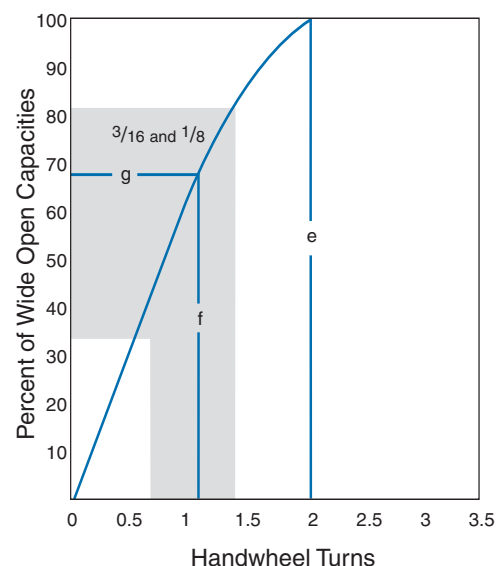
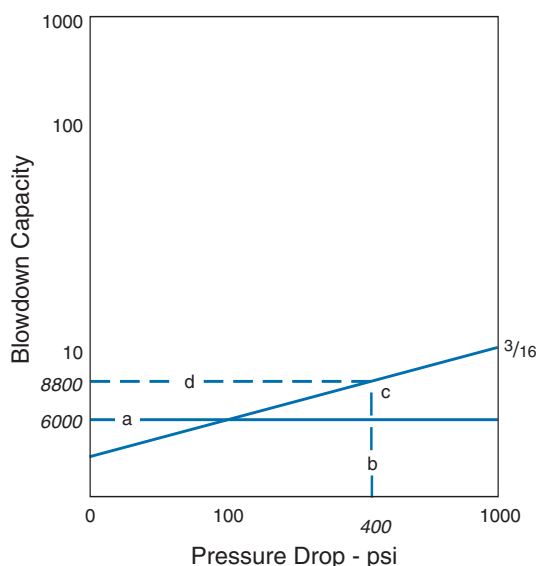
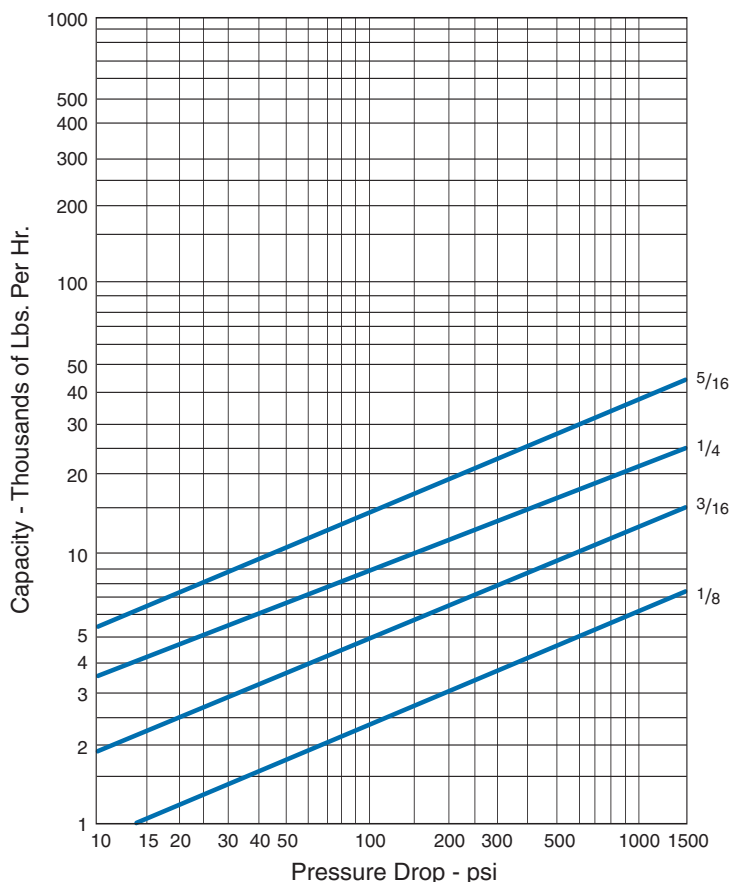

Steam Flow Chart

1" Figure Numbers 5505W (Reference #MM342)

Example 1: To determine the correct size orifice for an 800 Class Continuous Blowdown Valve which will flow 500 lbs/hr of steam at 600 psig inlet pressure with a pressure drop of 400 psi:

- A. On the Steam Flow chart to the right, locate 500 (0.5) on the Capacity scale and draw a horizontal line (a) across the chart from that point (see sample chart below).
- B. Draw a vertical line (b) from 600 on the Inlet Pressure scale to intersect with the horizontal line (a).
- C. Continue the vertical line (c) until it intersects with the next higher orifice curve (in this case, $\frac{3}{16}$ ").
- D. Draw a horizontal line (d) from the intersection of the $\frac{3}{16}$ " orifice curve to the Capacity scale and read the maximum capacity of the $\frac{3}{16}$ " orifice valve (780 lbs/hr).
- E. Check to ensure that the selected orifice will result in the correct valve position to allow for proper control without throttling too close to the seat (see steps F-I).
- F. On the Handwheel Turns vs Percent of Wide Open Capacities chart (see page 5), locate the $\frac{3}{16}$ " orifice curve and draw a vertical line (e) from where it intersects with the 100% open line, down to the Handwheel Turns scale (see sample chart below, right). Read the number of turns to reach maximum capacity of the valve (in this case, 2 turns).
- G. Calculate the percent of Wide Open Capacity necessary to attain the desired flow rate (divide the required capacity by the maximum capacity):
 $500/780 \times 100 = 64\%$
- H. Determine the number of turns open required to attain the required flow rate by drawing a horizontal line (f) from the 64% point on the Percent of Wide Open Capacities scale to intersect with the $\frac{3}{16}$ " orifice curve. Then draw a vertical line (g) from that intersection down to the Handwheel Turns scale. Read the number of handwheel turns needed to attain the desired flow (in this case, 1.20).
- I. Verify that the disc will be positioned within the proper range (between $\frac{1}{3}$ and $\frac{2}{3}$ open, which in this case is between 0.66 and 1.33 full turns)

Since 1.2 turns is well within the proper range of $\frac{2}{3}$ to $1\frac{1}{3}$ turns, the 1 inch valve with a $\frac{3}{16}$ " diameter orifice is satisfactory for the application and will allow for good control, both above and below the specified flow rate, without getting the disc too close to the seat.

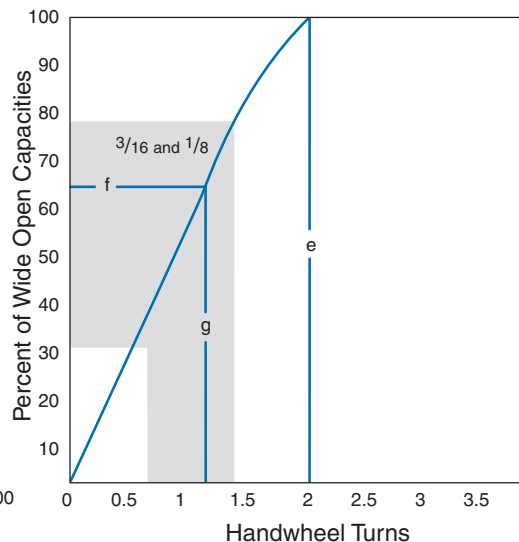
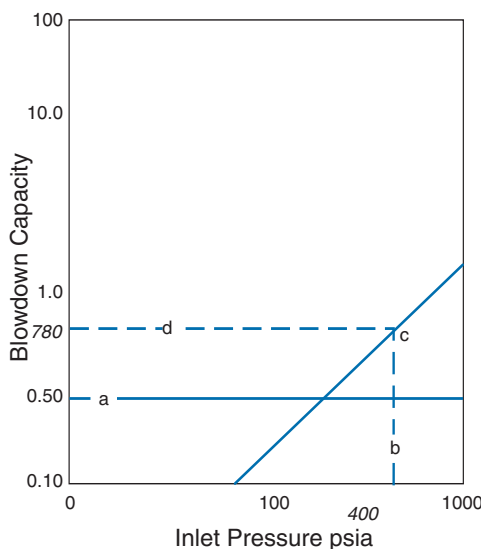
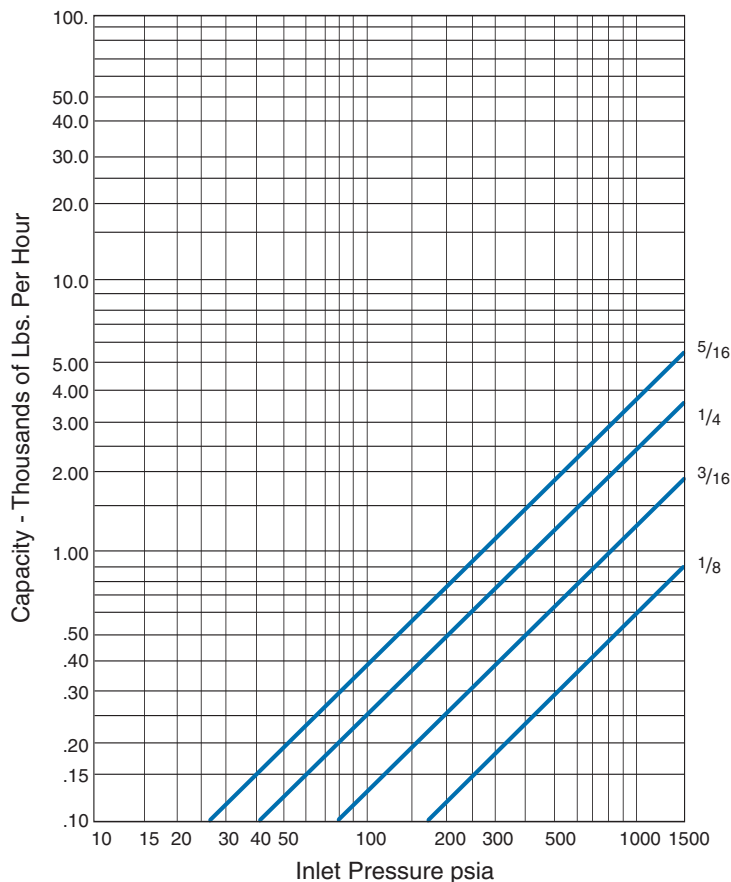

Flow Calculation Data and Formulas

The required valve size, flow rate or differential pressure can be determined from the nomographs on pages 4 through 7, or through the use of the formulas below. Flow Coefficients (C_v) can be found on page 3.

When determining the required valve size either through the use of flow coefficients (C_v) or the graphic method, it should be noted that the resultant valve size is the size that will give the required flow (or C_v) in the full open position. For optimum controllability, a control valve should be sized using a 25% greater flow capacity than the maximum required for the desired operating conditions. Selection of a valve on this basis allows for control variations above and below the calculated flow rate.

NOTE: For gas or steam, the maximum differential pressure (P) cannot exceed $1/2 P_1 - (\text{Minimum } P_2 = 1/2 P_1)$

The formulas shown may be used to calculate valve capacities or required flow coefficients.

Where:

C_v = Valve Flow Coefficient

P_1 = Inlet Pressure (psia)

P_2 = Outlet Pressure (psia)

ΔP = Pressure Drop (psi)

G = Specific Gravity of Liquid (water = 1.0)

$T(\text{SH})$ = Superheat °F = Total °F - Saturated °F

G_g = Specific Gravity of Gas (air @ one atm and 60°F = 1.0)

T = Absolute Temperature Upstream of Flowing Medium (0°F + 460)

Liquids:

$$Q = C_v \sqrt{\frac{\Delta P}{G}} \quad \text{OR} \quad C_v = \frac{Q}{\sqrt{\frac{\Delta P}{G}}}$$

Saturated Steam:

$$W = 2.1 C_v \sqrt{\Delta P(P_1 + P_2)} \quad \text{OR} \quad C_v = \frac{W}{2.1 \sqrt{\Delta P(P_1 + P_2)}}$$

Superheated Steam:

$$W = \frac{2.1 C_v}{1 + 0.0007T(\text{SH})} \sqrt{\Delta P(P_1 + P_2)} \quad \text{OR} \quad C_v = \frac{W [1 + .0007T(\text{SH})]}{2.1 \sqrt{\Delta P(P_1 + P_2)}}$$

Gas:

$$Q_g = 1360 C_v \sqrt{\frac{\Delta P}{G_g T}} \sqrt{\frac{(P_1 + P_2)}{2}} \quad \text{OR} \quad C_v = \frac{Q_g}{1360 \sqrt{\frac{\Delta P}{G_g T}} \sqrt{\frac{(P_1 + P_2)}{2}}}$$

Q = U.S. Gallons Per Minute = Mass Flow Rate In Pounds Per Hour

Q_g = Flow Rate of Gas or Vapor In Standard Cubic Feet Per Hour

W = Mass Flow Rate In Pounds Per Hour

When ordering Hancock valves, please specify:

- A. Quantity Required
- B. Valve Type
- C. Type of Connection - Socket Weld
- D. Operating Conditions
 - Working pressure
 - Temperature
 - Flow rate
 - Differential pressure
- E. Size of Connection - 1"
- F. Valve Style - Bolted bonnet OS&Y
- G. Body Material
- H. Trim Material
- I. Orifice Diameter

Example: 3 each, 1" Hancock Figure No. 5505W-2 High Pressure Drop Control Valve, ANSI 800 Class, manually operated, OS&Y, bolted bonnet, with solid Stellite seat ring, ASME SA105 body and bonnet and hard faced, 13% Cr. trim. End connections shall be socket weld. Valve must meet the requirements of ASME/ANSI B16.34, Section 1 of the ASME Boiler & Pressure Vessel Code and be suitable for use in the following service conditions:

Operating conditions:

Fluid = _____ at _____ psig and _____ °F;

Required flow rate = _____ lbs/hr .

Design conditions: Fluid = _____ psig and °F;

Design flow rate = _____ lbs/hr .

Figure Numbers Explained

Hancock Forged Steel Valves are available with a variety of standard and special materials, trims and operators. The diagram below is an explanation of Hancock figure numbers.

1" 5505 W — 000 - 1/4



Seat Orifice Size

1/8", 3/16", 1/4", 5/16"

Material Combination Suffix

No suffix indicates standard materials (SA105 body, stainless trim)

End Connection

W – Socket End

Valve Type Number

5505 High pressure drop globe valve, angle body, solid Stellite seat

Nominal Valve Size

1"