

HANCOCK®

Flow control valves combination valve and flow control instrument with special micrometer and pointer to set valve within 1/100 of a handwheel turn.

Features

- Available in Class 800 ANSI pressure classes, threaded (FNPT), and socket weld.
- Micrometer dial indicator is standard equipment to ensure accurate repeatable control settings.
- Valves are available with quadruple V-Port discs to ensure optimum controllability and flow.
- All internal surfaces are accurately machined to provide maximum performance.
- Renewable seat rings made from hardened stainless steel and faced with Stellite.
- The disc is hardened, ground and lapped for accurate, leak free sealing.
- Standard material is carbon steel body (ASME SA105) with 13% chrome stainless steel trim.
- GRAFOIL® packing is standard.
- Code compliance with ASME/ANSI B16.34 and the ASME Boiler and Pressure Vessel Code, Section I.

General applications

- Boilers, compressors, steam condensers, pumps, steam lines, feed water regulator bypass vents, liquid level control piping, flash tanks, soot blower connections, turbine generators, Dowtherm™, instrumentation, gauge shut-off.
- For refineries: alkalinization units, "cat" crackers, hydroformers, water-flooding, gas odorization.

Notes

1. GRAFOIL® is a registered trademark of GrafTech International Holdings Inc.
2. Dowtherm™ is a registered trademark of Dow Chemical Company.



Available Types and Sizes

- 5525S-2 T-Type, 4-V-port Disc, Threaded End to ANSI B1.20.1
- 5525W-2 T-Type, 4-V-port Disc, Socket Weld to ANSI B16.11
- 5535S-2 Angle Body, 4-V-port Disc, Threaded End to ANSI B1.20.1
- 5535W-2 Angle Body, 4-V-port Disc, Socket Weld to ANSI B16.11
- Sizes 1/2" - 2": ANSI 800 LTD Class

tyco / Flow Control

Total Flow Control Solutions™

Hancock is either a trademark or registered trademark of Tyco International Services AG or its affiliates in the United States and/or other countries. All other brand names, product names, or trademarks belong to their respective holders.

Features

Micrometer adjustment, for handwheel setting. Accurate adjustments can be made, to 1/10th handwheel turn, or for extremely fine setting, to 100th handwheel turn.

Graphite Packing Rings, with built in corrosion inhibitor for leak tight sealing at high and low pressures and temperatures.

Non-extrusion Rings, to prevent packing migration and ensure long service life in high pressure and high temperature service.

Accurately Guided Stem-Disc Connection, prevents spinning or vibration of disc.

Renewable Hard Faced Seats, (Stellite or equal) eliminate corrosion and steam cutting.

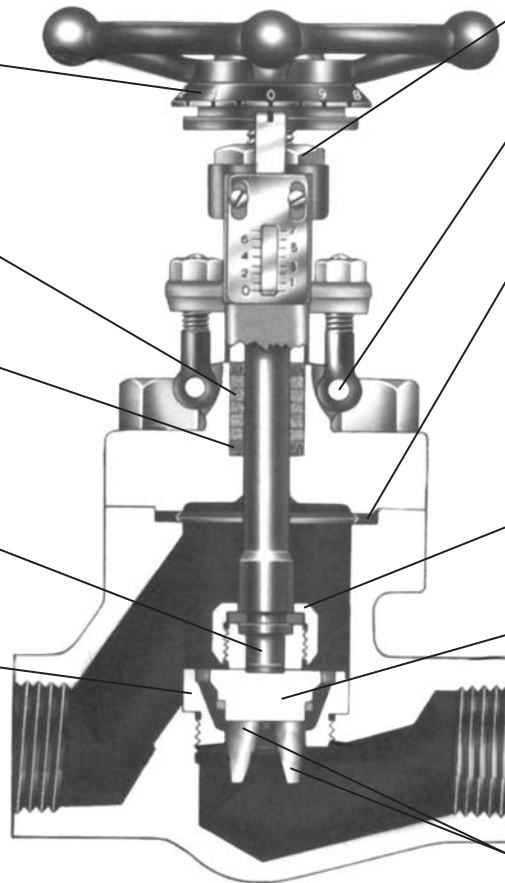

Stainless Steel Thread Bushing, eliminates corrosion attack.

Sturdy Swing Bolt Connections, hardened stainless steel pins.

Graphite Filled Stainless Gasket, with controlled compression for maximum corrosion resistance and zero leakage.

Unique Disc Nut, rolled-in against disc, forming positive, permanent lock.

Hardened Disc, provides excellent resistance to galling, corrosion and erosion.

Four "V" Port Construction is Standard, ports create flow proportional to handwheel turns.

Flow Control Operation

The Hancock Flow Control Valve is a combination valve and flow control instrument equipped with a special micrometer dial and pointer which enable the operator to set the valve opening to within one hundredth of a turn of the handwheel. Any desired setting can be instantly duplicated. Each valve is fitted with a scientifically designed V-Port valve disc ensuring proportional flow throughout the entire lift of the stem. It is a hand-operated

valve with a straight-line flow characteristic. A separate shut-off seating surface, removed from the controlling V-Ports, eliminates the necessity of using a second valve for shut-off purposes. Hancock Flow Control Valves ensure uniform quality by closer control of temperature and flow, save steam and fuel on process work and save money by reducing maintenance.

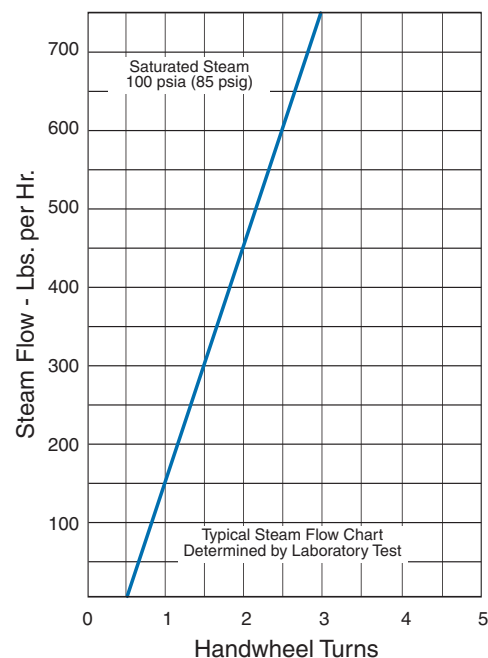

Disc and Seat Operation

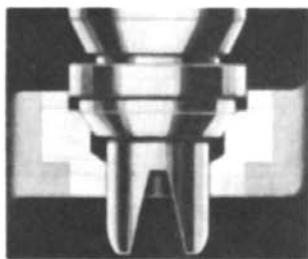

Valve seat and V-Port disc in fully closed position. Pressure is pushing upward under the disc. Note that the shut-off seating surface is entirely removed and separate from the flow-controlling V-Ports.

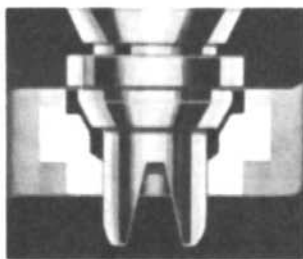

The valve in a slightly opened position. V-Port disc is allowing a measured flow of the media.

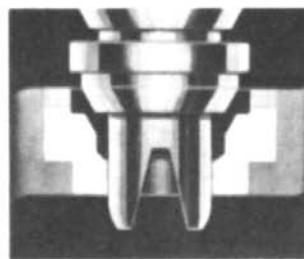

In this intermediate position, V-Port disc is allowing a proportionally greater flow of the media.

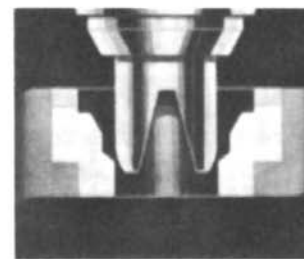

Valve fully opened allowing maximum flow. Any open position can be accurately duplicated by the use of the special micrometer dial and pointer.

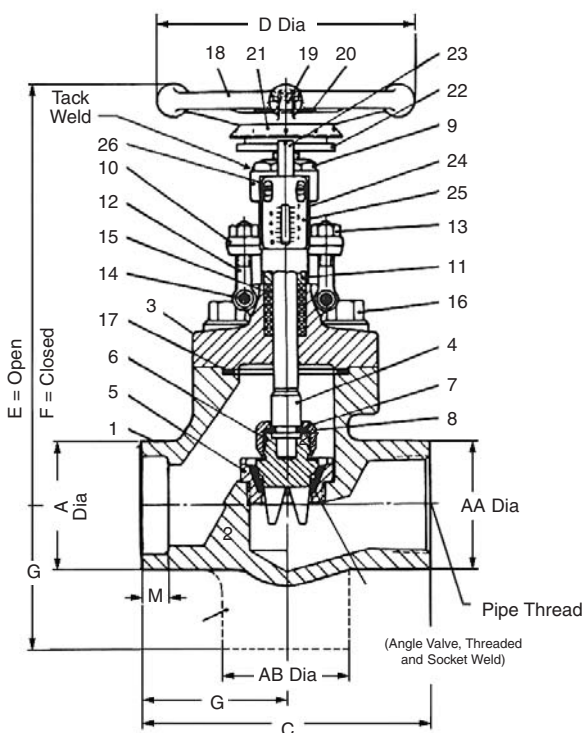

Materials of Construction

No.	Part	Material	Specification
1	Body (Globe)	Forged Carbon Steel	ASME SA105
2	Body (Angle)	Forged Carbon Steel	ASME SA105
3	Bonnet	Forged Carbon Steel	ASME SA105
4	Stem	Stainless Steel	420
5	Seat	Stainless Steel	410
6	Disc	Stainless Steel	410
7	Disc Nut	Carbon Steel	410
8	Lock Ring	Stainless Steel	410 HT
9	Threaded Bushing	Stainless Steel	410
10	Packing Gland Flange	Carbon Steel	410
11	Packing Gland	Stainless Steel	410
12	Packing Gland Bolt	Stainless Steel	410 HT
13	Packing Gland Nut	Carbon Steel	ASTM A194-2H
14	Pin	Stainless Steel	410
15	Packing Ring	Compressed Graphite	Lubricated and Corrosion Inhibited
16	Bonnet Bolt	Alloy Steel	ASTM A193 Gr. B-7
17	Gasket	304 Stainless Steel Graphite Filled	Spiral Wound
18	Handwheel	Ductile Iron	Phosphated
19	Handwheel Nut	Carbon Steel	Lock-Type
20	Marker Plate	Stainless Steel	304
21	Dial	Brass	—
22	Dial Plate	Brass	—
23	Indicator	Brass	—
24	Indicator Bracket	Aluminum	—
25	Indicator Plate	Aluminum	—
26	Indicator Plate Screw	Steel	Cadmium Plated
27	Seat Facing	Hard Facing	Stellite or Equal

Dimensions, Weights and C_v Values

Size	A	AA	C	D	E	F	G	H	M	Weight	4 V-Port
1/2	15/16	15/16	35/16	3 1/2	5 15/16	5 3/4	12 1/32	0.855	3/8	5	1.00
3/4	1 1/2	1 1/2	39/16	3 1/2	6 3/8	6 1/8	12 25/32	1.065	1/2	5 1/4	2.00
1	1 7/8	1 7/8	4 3/8	4	7 3/4	7 3/8	23 1/16	1.330	1/2	8 1/2	4.00
1 1/2	2 1/2	2 1/2	6 1/2	5 1/2	9 5/8	9 1/32	3 1/4	1.915	1/2	17 1/2	10.40
2	3 1/8	3 1/8	7	6 1/2	11 1/16	10 5/16	3 1/2	2.406	5/8	27	14.00

Air Flow

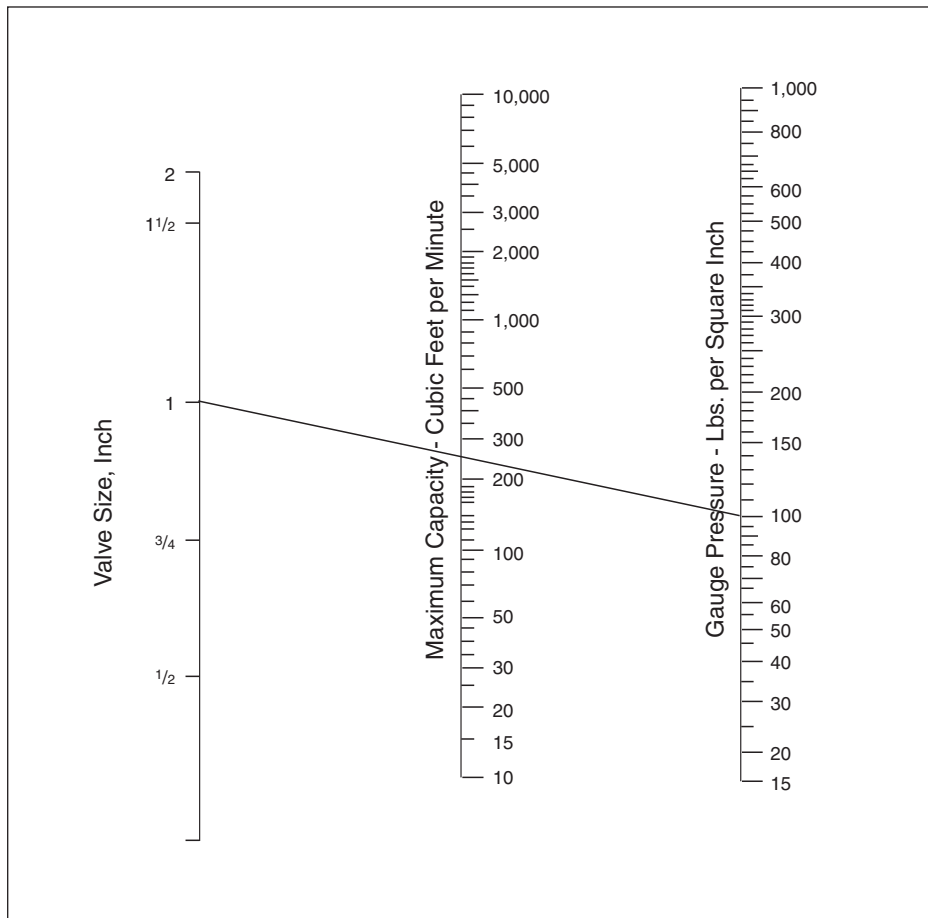

For air at 70°F only. For other gases, divide capacity by square root of specific gravity. If outlet pressure is greater than 55% of the inlet pressure, multiply capacity by the correction factor on Chart #1 below. 4 V-Port valves only.

Flow Chart Correction Factors

Steam, Air, Gas
Chart #1

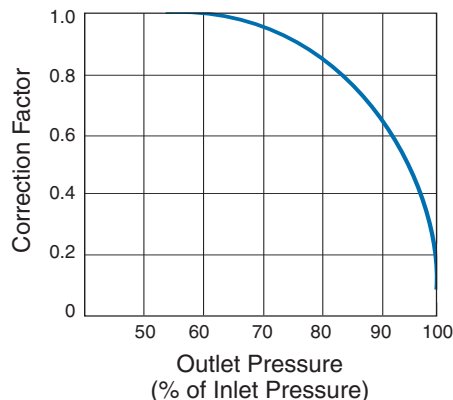

Air Flow Chart, 800 Class Steel - Types 5525 and 5535

Example 1:

To determine the maximum flow rate of a 1" figure 5525, 4 V-Port flow control valve flowing 70°F air to atmosphere at 100 psig inlet pressure:

- Using the Air Flow Chart nomograph to the left, locate the correct valve nominal size (1") on the Valve Size scale.
- Locate 100 on the Gauge Pressure scale and then draw a straight line from that point to the 1" point on the Valve Size scale.
- Read the maximum flow rate at the point where the drawn line intersects the Maximum Capacity scale. In this case, the correct reading would be 250 cubic feet per minute and since the outlet pressure is less than 55% of the inlet pressure, no flow correction is needed.

Example 2:

To determine the maximum flow rate of a 1", 4 V-Port flow control valve flowing 70°F air at 100 psig inlet pressure and an outlet pressure of 75 psig:

- Determine the maximum 1" valve capacity as in Example 1. Since the outlet pressure is greater than 55% of the inlet pressure (in this case 75%), the capacity must be multiplied by the appropriate Correction Factor.
- To determine the Correction Factor, locate the 75% point on the Outlet Pressure axis of Chart 1 and draw a vertical line from that point to intersect with the graph curve. Then draw a horizontal line from that intersection to the Correction Factor axis and read the Correction Factor corresponding to that intersection point (0.88 in this case).
- Multiply the flow capacity (250 ft³/min) by the Correction Factor determined in Step B above to calculate the correct capacity (250 x 0.88 = 220 ft³/min).

Steam Flow Chart, 800 Class Steel Types 5525 and 5535

Example 1:

To determine the maximum flow rate of a 1 1/2" figure 5525, 4 V-Port flow control valve flowing saturated steam to atmosphere at 100 psia inlet pressure:

- A. Using the Steam Flow Chart nomograph at the right, locate the correct valve nominal size (1 1/2") on the Valve Size scale.
- B. Locate 100 on the Absolute Pressure scale* and then draw a straight line from that point to the 1 1/2" point on the Valve Size scale.
- C. Read the maximum flow rate at the point where the drawn line intersects the Maximum Capacity scale. In this case the correct reading would be 1750 pounds per hour and since outlet pressure is less than 55% of the inlet pressure, no flow correction is required.

Example 2:

To determine the maximum flow rate of a 1 1/2" figure 5525, 4 V-Port flow control valve flowing saturated steam to atmosphere at 100 psia inlet pressure and an outlet pressure of 90 psia:

- A. Determine the maximum 1 1/2" valve capacity as in Example 1. Since the outlet pressure is greater than 55% of the inlet pressure (in this case 90%), the capacity must be multiplied by the appropriate Correction Factor.
- B. To determine the Correction Factor, locate the 90% point on the Outlet Pressure axis of Chart 1 and draw a vertical line from that point to intersect with the graph curve. Then draw a horizontal line from that intersection to the Correction Factor axis and read the Correction Factor corresponding to that intersection point (0.65 in this case).
- C. Multiply the flow capacity (1750 lbs/hr) by the Correction Factor determined in Step B above to calculate the correct capacity (1750 x 0.65 = 1138 lbs/hr).

* Absolute pressure = Gauge Pressure (psi) + 14.7

Steam Flow

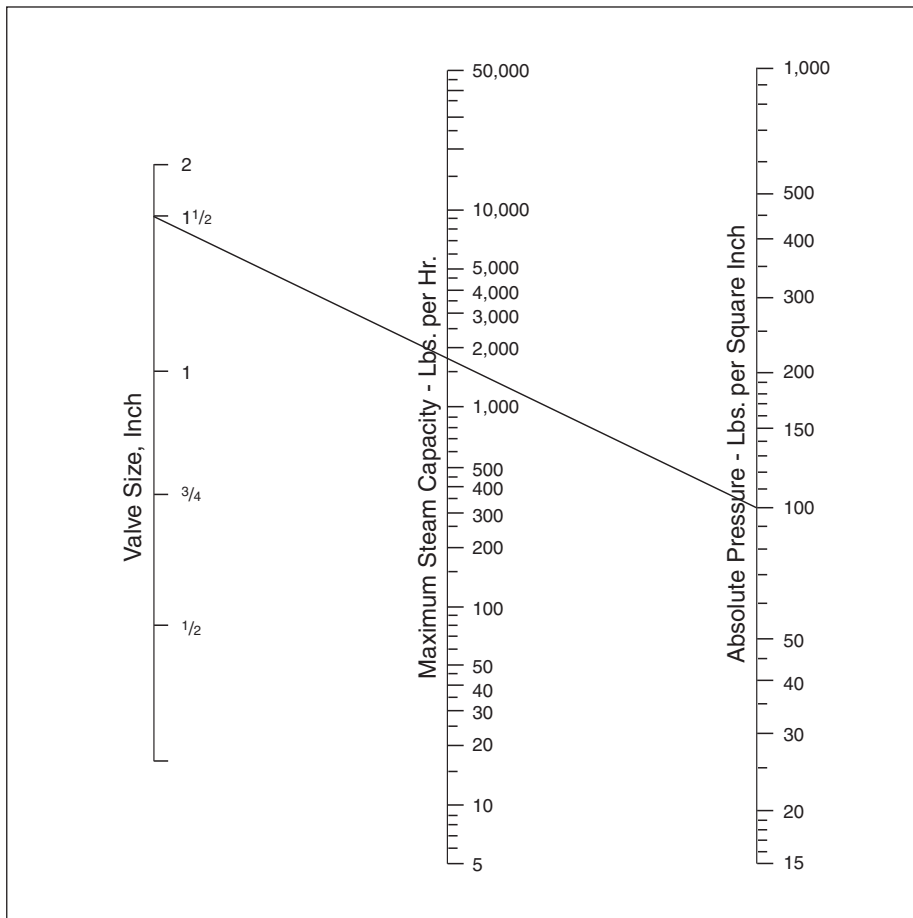

If outlet pressure is greater than 55% of the inlet pressure, multiply capacity by the correction factor on Chart #1 below. For superheated steam, multiply by correction factor on Chart #2 below. 4 V-Port valves.

Flow Chart Correction Factors

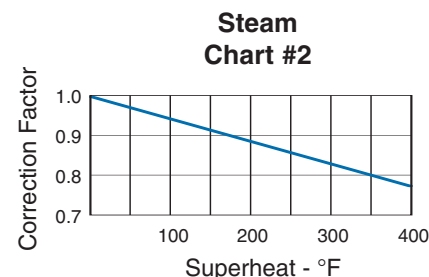
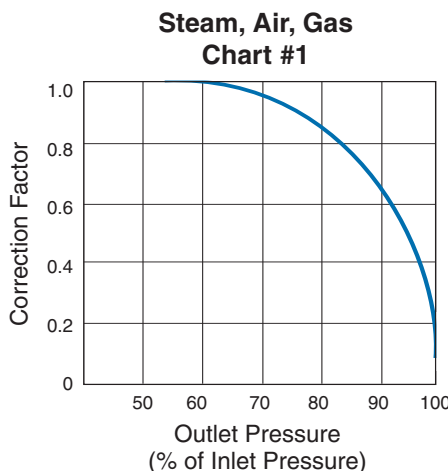

Boiler Blowdown

Boiler Blowdown Chart, 800 Class Steel - Type 5535

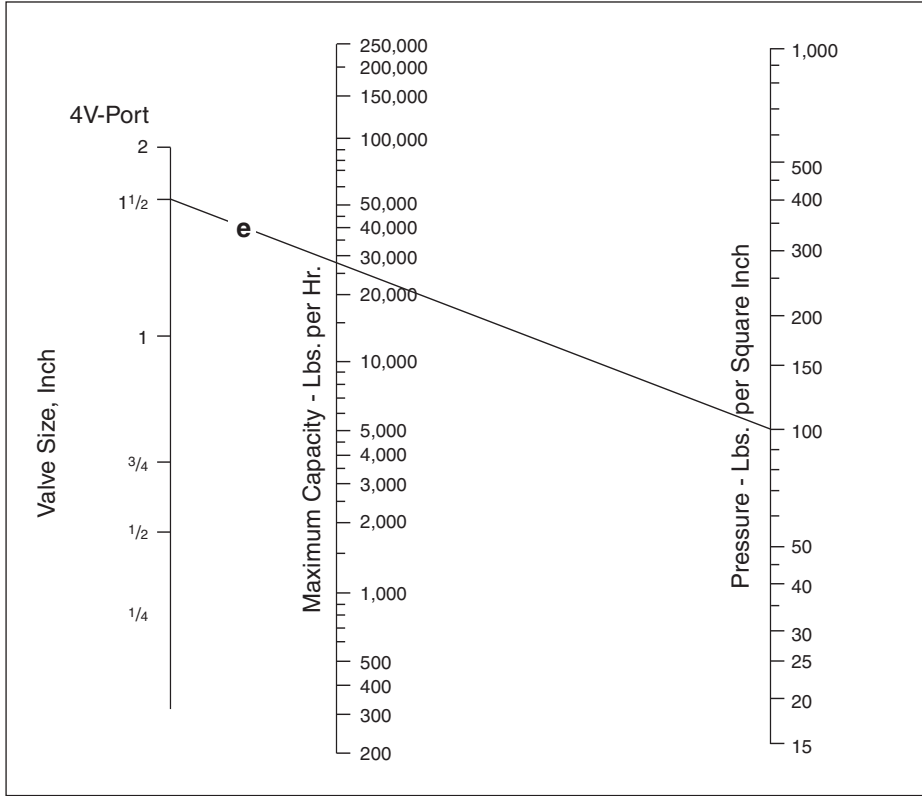

NOTE: For blowdown service, flow must be over the disc.

Example 1:

To determine the correct size 800 Class Figure 5535 angle flow control valve to be used for continuous blowdown service which will be capable of attaining a maximum required flow of 18,000 lbs/hr at 100 psig inlet pressure and a normal flow rate of 9,900 lbs/hr at 100 psig:

- On the Boiler Blowdown Chart to the left, locate 18,000 on the Maximum Capacity scale.
- Locate 100 on the Pressure scale and then draw a line from that point on the Boiler Pressure scale, through the 18,000 point located on the Maximum Capacity scale, and then extend the line until it intersects with the Valve Size scale.
- Read the correct valve size (to attain maximum flow) at that point (in this case, 1 1/2"). In the event that the intersection falls between the two valve sizes, select the next larger size.
- Check to ensure that the selected valve will result in the correct valve position to allow for proper control at the required NORMAL flow rate without throttling too close to the seat. The optimum disc position (for good control with maximum seat life) would be from 1/3 to 2/3 open and the selected valve should be capable of passing the desired normal flow capacity when the valve disc is positioned within this range.
- Determine the maximum flow rate of the valve, locate 100 on the pressure scale and then draw a line from that point on the valve size, then read the flow in lb. per hr. (in this case, 28,000 lb./hr.).
- Determine what percent of the full open capacity is required to attain the "Normal" Required Flow Rate. (Divide the Normal Required Flow Rate by the Maximum Flow Rate and multiply by 100 to attain the correct percentage:

$$9,900 \text{ lbs/hr} / 28,000 \text{ lbs/hr} \times 100 = 35.4\%$$
- Verify the required flow rate is obtained when the valve is between 1/3 and 2/3 open (between 2 1/6 and 4 full turns) by drawing a horizontal line (f) from the 35% mark on the Percent of Wide Open Capacity scale to intersect with the 1 1/2" valve curve scale. Draw a vertical line (g) from that intersection down to the Handwheel Turns scale and read the number of turns open (2 1/3) required to attain the specified "Normal" Flow Rate. In this case, 2 1/3 turns is well within the 12/3 to 3 1/3 turns required for optimum flow control and the 1 1/2" valve size is correct.

Handwheel Turns vs. Percent of Wide Open Capacities

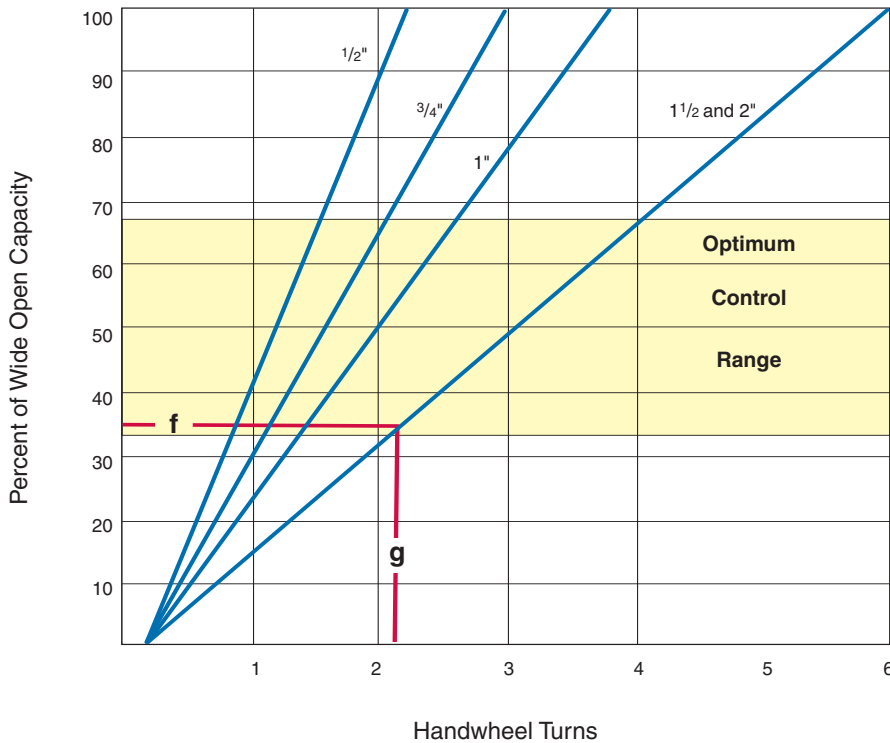

Water Flow Chart, 800 Class Steel Types 5525 and 5535

Example 1:

To determine the maximum flow rate of a 2" figure 5525, 4 V-Port flow control valve flowing water at 100 psig inlet pressure and 90 psig outlet pressure:

- A. Using the Water Flow Chart nomograph to the right, locate the correct valve size (2") on the Valve Size scale.
- B. Calculate the differential pressure across the valve (inlet pressure minus outlet pressure = differential pressure) in this case the differential pressure is 10.
(100 - 90 = 10)
- C. Locate 10 on the Pressure Drop scale and then draw a straight line from that point to the 2" point on the Valve Size scale.
- D. Read the maximum flow rate at the point where the drawn line intersects the Maximum Capacity scale. In this case, the correct reading would be 2500 U.S. gallons per hour.

Water Flow

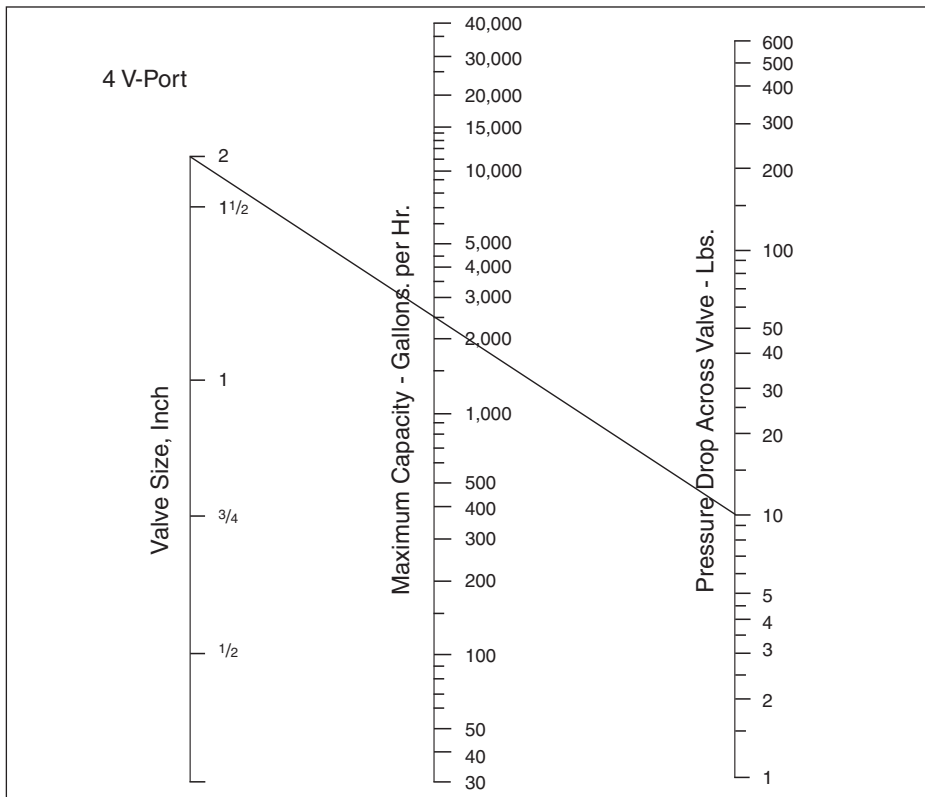

Flow Calculation Data and Formulas

The required valve size, flow rate or differential pressure can be determined from the nomographs on Pages 4 through 6, or through the use of the formulas below. Flow Coefficients (C_v) can be found on Page 3.

When determining the required valve size either through the use of flow coefficients (C_v) or the graphic method, it should be noted that the resultant valve size is the size that will give the required flow (or C_v) in the full open position. For optimum controllability, a control valve should be sized using a 25% greater flow capacity than the maximum required for the desired operating conditions. Selection of a valve on this basis allows for control variations above and below the calculated flow rate.

NOTE: For gas or steam, the maximum differential pressure (P) cannot exceed $1/2 P_1$. (Minimum $P_2 = 1/2 P_1$)

The formulas shown may be used to calculate valve capacities or required flow coefficients.

Where:

- C_v = Valve Flow Coefficient
- P_1 = Inlet Pressure (psia)
- P_2 = Outlet Pressure (psia)
- ΔP = Pressure Drop (psi)
- G = Specific Gravity of Liquid (water = 1.0)
- $T_{(sh)}$ = Superheat °F – Saturated °F
- G_g = Specific Gravity of Gas (air @ one atm and 60°F = 1.0)
- T = Absolute Temperature Upstream of Flowing Medium (°F + 460)

Q = U.S. Gallons Per Minute

W = Mass Flow Rate In Pounds Per Hour

Q_g = Flow Rate of Gas or Vapor In Standard Cubic Feet Per Hour

Liquids:

$$Q = C_v \sqrt{\frac{\Delta P}{G}} \quad \text{OR} \quad C_v = \frac{Q}{\sqrt{\frac{\Delta P}{G}}}$$

Saturated Steam:

$$W = 2.1 C_v \sqrt{\Delta P(P_1 + P_2)} \quad \text{OR} \quad C_v = \frac{W}{2.1 \sqrt{\Delta P(P_1 + P_2)}}$$

Superheated Steam:

$$W = \frac{2.1 C_v}{1 + 0.0007T_{(sh)}} \sqrt{\Delta P(P_1 + P_2)} \quad \text{OR} \quad C_v = \frac{W [1 + .0007T_{(sh)}]}{2.1 \sqrt{\Delta P(P_1 + P_2)}}$$

Gas:

$$Q_g = 1360 C_v \sqrt{\frac{\Delta P}{G_g T}} \sqrt{\frac{(P_1 + P_2)}{2}} \quad \text{OR} \quad C_v = \frac{Q_g}{1360 \sqrt{\frac{\Delta P}{G_g T}} \sqrt{\frac{(P_1 + P_2)}{2}}}$$

Figure Numbers Explained

Hancock Forged Steel Valves are available with a variety of standard and special materials, trims and operators. The diagram below is an explanation of Hancock figure numbers.

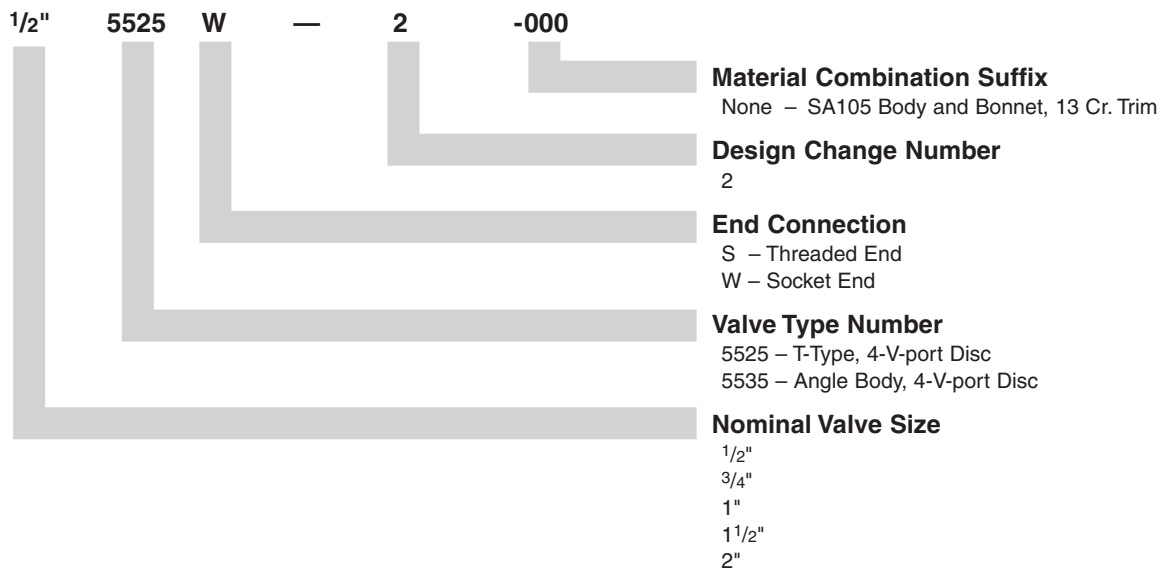

www.tycoflowcontrol.com

Tyco Flow Control (TFC) provides the information herein in good faith but makes no representation as to its comprehensiveness or accuracy. This data sheet is intended only as a guide to TFC products and services. Individuals using this data sheet must exercise their independent judgment in evaluating product selection and determining product appropriateness for their particular purpose and system requirements. TFC MAKES NO REPRESENTATIONS OR WARRANTIES, EITHER EXPRESS OR IMPLIED, INCLUDING WITHOUT LIMITATION ANY WARRANTIES OF MERCHANTABILITY OR FITNESS FOR A PARTICULAR PURPOSE WITH RESPECT TO THE INFORMATION SET FORTH HEREIN OR THE PRODUCT(S) TO WHICH THE INFORMATION REFERS. ACCORDINGLY, TFC WILL NOT BE RESPONSIBLE FOR DAMAGES (OF ANY KIND OR NATURE, INCLUDING INCIDENTAL, INDIRECT, OR CONSEQUENTIAL DAMAGES) RESULTING FROM THE USE OF OR RELIANCE UPON THIS INFORMATION. Patents and Patents Pending in the U.S. and foreign countries. Tyco reserves the right to change product designs and specifications without notice.